



www.daytonohio.gov

STANDARDS

For

Taps, Services, Meters, and Backflow Prevention

January 1, 2024

Michael Powell – Director, Department of Water



City of Dayton, Building Services
371 West Second Street
Dayton, Ohio 45402
Phone: 937-333-6804
Fax: 937-333-6809

City of Dayton, Water Engineering
320 West Monument Avenue
Dayton, Ohio 45402
Phone: 937-333-3725
Fax: 937-333-8555

CITY OF DAYTON

DEPARTMENT OF WATER

STANDARDS FOR TAPS, SERVICES, METERS, AND BACKFLOW PREVENTION

APPROVED:

Aaron S. Zonin Digitally signed by Aaron S. Zonin
Date: 2023.12.20 15:06:46 -05'00'

Michael Powell, Director
Department of Water

Date

1. GENERAL

The Standards for Taps, Services, Meters and Backflow Prevention, in conformance with established practices by the City of Dayton, Department of Water (City), apply to all residential, commercial, industrial, multi-family developments and capital improvements involving the construction, modification, addition, or replacement of water and sewer piping systems (services) under the jurisdiction of the City or through agreements with other governmental authorities. These standards shall be used in conjunction with all other applicable standards that include but not necessarily limited to:

1. City of Dayton Water Engineering Design Standards for Water, Sanitary Sewer and Storm Sewer Facilities
2. City of Dayton Construction and Materials Specifications
3. City of Dayton Department of Public Works Rules and Regulations for Making Openings in a Public Way
4. City of Dayton Department of Water Rules and Regulations

Standards are available online at <https://www.daytonohio.gov/850/Standards-Specifications-Rules-Regulatio>.

2. PLAN SUBMITTAL

Plans shall be submitted for any water service larger than one inch (1”) in diameter to the One Stop Shop, Division of Water Engineering for approval, on the second floor at 371 West 2nd Street. [Phone (937) 333-6804 or fax (937) 333-6809]. Plans must show Contractor name, service address; service size and type; metering and backflow concept; and all other details essential to plan review; or as requested. Plans must be approved, and service permit(s) issued prior to the start of any work.

3. WATER AND SEWER TAP AND SERVICE PROCEDURES

The City of Dayton makes all service taps within the City of Dayton and in any areas outside of the City that are not within master meter area, unless amended by agreement. The City’s Division of Water Utility Field Operations (WUFO) performs the tap and piping service in the following areas:

AREA	WATER TAP	SEWER TAP*	WATER SERVICE	SEWER SERVICE
City – Right of Way	X	X	X	X
City – Easements	X			
City – Private Streets	X			
City – New Plats	X			
Brookville	X			
Clayton (Crestway & N. of I-70)	X			
Greene County (W. of I-675)	X			
Trotwood (Old)	X			
Trotwood (New – MC Area)	X			
Montgomery County (Non-Master Meter Areas)	X			

*Sewer includes both Sanitary and Storm

*City makes Taps on Clay Pipe Only; Tapping a Concrete Pipe or a Manhole shall be done by the Contractor using core drilling methods at their expense

A. Within City Limits

- Plans approved by Water Engineering.
- Service Permit obtained and Work Order written.
- Water Tap and Service in Right of Way – City provides all labor, equipment, and materials; and makes tap and installs service to the curb stop that is typically at the property line as marked out by the Contractor and City staff. City does all excavation and restoration.
- Water Tap Only, made in Easements, Private Streets and New Plats – Contractor does all excavation and restoration; City makes tap only and provides corporation stop, saddles, and tapping sleeves and valves; as applicable. Contractor provides all labor, equipment, and other materials (piping material, valve box, backfill, asphalt, concrete, etc).
- Sewer Tap and Service in the Right of Way – City provides all labor, equipment, and materials with the exception of any core drilling. The City shall make the tap on clay pipe, the Contractor shall tap any concrete pipe. For concrete pipe, manholes or any other concrete structure, the Contractor shall make the tap by core drilling at their expense. The City installs the service to property line as marked out by the Contractor and City staff. City shall do all excavation and restoration.

B. Outside City Limits

(City makes Water Tap Only)

Clayton – Crestway & North of I-70

The City makes “water tap only” per the following procedure:

- Plans approved by Water Engineering.
- Service Permit obtained and Work Order written
- Contractor to contact Clayton to notify Clayton of work. A Right-of-Way and/or Street Cut permit may be required from Clayton. Contractor is responsible for any permit required by Clayton.
- The tapping location will be marked by the City and Contractor.
- Contractor does all excavation and restoration; City makes water tap and provides corporation stop, saddles, and tapping sleeves and valves; as applicable. Contractor provides all labor, equipment, and other materials (valve box, meter pit, etc) for service installation.

Brookville, Greene County (West of I-675), Trotwood (old)

The City makes “water tap only” per the following procedure:

- Plans approved by the Service Area and when appropriate, the local Fire Department; and then City second. The Contractor must inform the Service Area of any substantive changes to the plans required to satisfy the City’s requirements.
- Permit(s) obtained, and fees paid to Service Area, then a Water Service Permit is obtained from the City.
- Work Order written by the City.
- Tap location marked on site by the Contractor with assistance from the Service Area personnel.
- Contractor does all excavation and restoration; City makes tap and provides corporation stop, saddles, and tapping sleeves and valves; as applicable. Contractor provides all labor, equipment, and other materials (valve box, meter pit, etc) for service installation. Exception is in Brookville where the contractor provides the tapping sleeve and valve for sizes 4” and greater to the City for installation. 4” and greater valves in Brookville must open left or counter-clockwise. Valve provided to the City by the Contractor must be compatible to the City’s tapping machine.

Montgomery County - Clayton (south of I-70 except Crestway), Englewood (south of I-70), Kettering (areas not behind master meter), Riverside, Trotwood (new), Vandalia (south of I-70), and parts of Butler, Clay and Harrison Townships. Excludes Shiloh, Northridge, and Drexel Master Metered Areas, and the Greater Moraine Area.

In Service Areas under direct contract for water with the City and not behind a master meter, the City makes “water taps only” per the following procedure:

- Plans approved by County and when appropriate the local Fire Department.
- Permit(s) obtained and tapping fees paid by Contractor to County. City will collect tapping fees from County.
- Tap location marked on site by the Contractor with assistance from County personnel.
- Material per County specifications.
- Contractor does all excavation and restoration; City makes tap and provides corporation stop, saddles, and tapping sleeves and valves; as applicable. Contractor provides all labor, equipment, and other materials (valve box, meter pit, etc.) for service installation.

4. WATER METERS

Metering plans must be approved prior to installation of new or resumed water service for meters one- and one-half inches (1-1/2”) or larger. All new meter spreads and piping shall comply with the Standards for Taps, Services, Meters and Backflow Prevention. Meter spreads and piping for services being resumed shall be brought up to current standards. Openings are prohibited ahead of the meter except for ¼” outlets for pressure gauges.

5. FIRE LINE SERVICES

All fire suppression systems require plan approval from the Department of Fire, the Department of Building Services, and the Department of Water. The plan shall show the size and type of pipe to be used, location of valves, hydrants, Siamese connections, check valves, backflow preventers, and other appurtenances. The installation methods and materials shall comply with the current edition of NFPA #24, “Standard for the Installation of Private Fire Service Mains” except as otherwise specified in the City Water Service Standards or the Ohio Building Code. The minimum permitted fire line size is two inches (2”) in diameter and all materials shall be new.

6. BACKFLOW PREVENTION

All water services, whether new or resumed, shall be investigated and analyzed for backflow prevention and cross connection control. Cross connections are prohibited, and all installations must conform to the backflow prevention portion of the Rules and Regulations of the Department of Water, the requirements of the Ohio Environmental Protection Agency and the Ohio Department of Commerce. All backflow prevention devices (types ASSE 1013, 1015, and 1020) shall be installed in accordance with the Department of Water and Plumbing Inspection's current procedures for plans, permits and inspections.

7. ADDITIONAL INFORMATION

All taps on the City-maintained water distribution system, wastewater collection system, or stormwater drainage system shall be made or supervised by personnel of the Department of Water. Water taps shall be made by the City in areas outside of the corporation limits that are not served through a master meter, except as modified by agreement.

For "Water Main Extension" work within the City Limits, the Contractor will perform all the work except for the tapping of the water main which will be performed by the City at the Contractor's expense. The cost of the tap will be in accordance with the Schedule of Prices with an Estimate obtained by the Contractor by calling 937-333-3725.

For "Sewer (Storm and Sanitary) Main Extension" work within the City Limits, the Contractor will do all the work that includes tapping of the sewer main. The Contractor will perform all excavation, installation, backfilling, and surface restoration in accordance with all applicable standards.

Under no circumstance can a lead water service be picked up or used. All lead shall be replaced if the service is being replaced.

For "Tap Only" work, the Contractor will perform all excavation, piping installation, backfilling, and surface restoration in accordance with all applicable standards.

The Contractor may be required to provide heavy equipment to lower and hold in place the tapping sleeve and valve at no cost to the City.

For Sewer service work, the City does not core into any manhole or catch basin. If coring is required, then the Contractor shall provide this service prior to the City's work.

The City shall do all repair work in the Right of Way. The customer will be charged for any repair work on the private sanitary lateral and cost must be paid in advance.

The tapping location within City limits will be marked by the Contractor with City's assistance.

Ohio Utility Protections Services (OUPS) must be contacted a minimum of 48-hour in advance of marking the tap location.

A 48-hour notice is required for making taps. No taps on Monday of Friday unless approved by the City.

The property or easement line within City limits will be marked by the Contractor prior to tapping.

Call 937-333-4901 to arrange an appointment for water service; 937-333-4918 for sewer service.

WATER AND SEWER SERVICE INSTALLATION COSTS

The following is the schedule of prices to be charged by the City of Dayton, Department of Water (City), for WATER and SEWER SERVICE taps, excavation, installation of pipe, backfilling and restoration of the surfaces in streets and alleys on and after January 1, 2024. The City reserves the right to review and adjust cost on an annual basis.

1. SCHEDULE OF PRICES

A. 2” and Smaller Water Service Taps

The below cost is for water taps two inches (2”) and smaller. These costs are in addition to the cost for small service piping cost in Section 1.B. Water and Sewer Service Piping Installation – Small Services.

SIZE	TAP ONLY C.I. & D.I. (1)	TAP ONLY CONCRETE (2)
1”	\$320	\$ 1,255
1 ½”	\$590	\$ 1,340
2”	\$810	\$ 1,525

ADJUSTED FOR 2026

Aaron S. Zonin Digitally signed by Aaron S. Zonin
Date: 2026.03.04 13:49:16 -05'00'

APPROVED BY

- 1 - Includes corporation stop and saddles for cast and ductile iron pipes
- 2 - Allow 6 weeks for obtaining saddles or tap sleeves for concrete taps.

The cost shall be paid in advance prior to any work being performed. Call 937-333-3725 for a cost estimate.

B. Water and Sewer Piping Installation – Small Services

Small services are one to two inches (1”–2”) for water; and six inches (6”) for sewer.

Material cost shall be charged at the current market price as determined by the actual cost plus a 15% mark-up for handling. Material includes k-copper piping, curb stop(s) and box for water services; PVC piping and tapping saddles for sewer services.

Excavation and restoration for installing a new service from the main in the street to the property line shall be charged based on the depth of the trench per the below chart. The cost includes labor and equipment to excavate, install the piping, street and trench restoration, concrete work, and sod restoration.

Trench Depth In Feet	Class 1 Concrete Pavement Cost Per L.F.	Class 2 Brick On Concrete Base Cost Per L.F.	Class 3 Asphalt on Concrete Base Cost Per L.F.	Class 4 Asphalt on Brick Base Cost Per L.F.	Class 5 Asphalt on Stone Or Gravel Base Cost Per L.F.
0 - 5	\$ 350	\$ 400	\$ 300	\$ 400	\$ 250
>5 - 10	\$ 400	\$ 450	\$ 350	\$ 450	\$ 300
>10 - 15	\$ 450	\$ 500	\$ 400	\$ 500	\$ 350
Trench Depth In Feet	Class 6 Gravel Roadway Plain Or Oiled Cost Per L.F.	Class 7 Concrete Sidewalks Or Driveways Cost Per L.F.	Class 8 Sodded Areas Cost per L.F.	Class 9 Grass Or Unimproved Areas Cost Per L.F.	
0 – 5	\$ 200	\$ 250	\$ 250	\$ 250	
>5 - 10	\$ 250	\$ 300	\$ 300	\$ 300	
>10 - 15	\$ 300	\$ 350	\$ 350	\$ 350	

This does not include the cost of the water taps or services 4” and larger; or sewer services 8” and larger.

This does not cover the cost of the service and street cut permits; those costs are additional.

The minimum charge for any water and sewer service installation will be ten (10) linear feet for Class 1 thru 5; five (5) linear feet for Class 6 – 9. When the restoration includes work from multiple classes, minimums may apply separately.

The minimum charge for a sanitary sewer lateral repair will be six (6) feet for all street classification.

Trenches deeper than 15’ will be estimated on a per service basis.

Rock excavation will be charged at the rate of \$350.00 per cubic yard in addition to the preceding charges.

Services located in the area deemed the “central business district” will be charged actual cost per service for installation.

Water service installed by pulling or hole hogging, the work will be charged a flat rate of \$4000 plus any permit charges. The feasibility of no-dig installations is dependent upon the soil conditions and the presence of conflicting utilities.

The cost shall be paid in advance prior to any work being performed. Call 937-333-3725 for a cost estimate.

Contractor to call Civil Engineering at 937-333-3838 to obtain street classification and cost for the street cut permit.

Contact Water Engineering at 937-333-3725 for assistance in determining the charges.

C. Water and Sewer Piping Installation – Large Services

Large services are four inches (4”) and larger for water; and eight inches (8”) and larger for sewer.

Water taps and services four inches (4”) and larger; and sewer taps and services eight inches (8”) and larger shall be estimated by the City and charged at the prevailing rates for labor, material, equipment, material handling, fringe benefits and indirect costs.

All cost shall be paid in advance after plans have been approved and the service permit secured.

Cost shall be based on Approved Plans. Cost may be adjusted after work is completed.

Call 937-333-3725 for a cost estimate.

2. PERMITS

A. Service Permits

Cost above in Schedule of Prices, does not include the cost for water and/or sewer service permits. Work will not start until the permit(s) has been secured and any applicable assessment fees are paid.

Contractor shall obtain and pay for the permit at the City's One Stop Shop, located at 371 W. Second St, Dayton, Ohio 45402. Contact One Stop Shop (937-333-6804) to determine the cost of the permit.

B. Street Cut Permits

Cost above in Schedule of Prices, does not include the cost for the street cut permit. The Contractor will be charged the current fee for a street cut permit(s) and surcharges as established by Public Works and costs are subject to annual adjustments. Additional surcharges will be made for street cuts in recently paved streets. Contractor shall see City of Dayton, Department of Public Works, Rules and Regulations for Making Openings in a Public Ways, latest edition, for all cost, rules, and regulations, located here at: <https://www.daytonohio.gov/DocumentCenter/View/705/Street-Cut-Rules-and-Regulations-DF?bidId=>. The cost for the street cut permit will be added to the Contractor's invoice.

Contact Civil Engineering at 937-333-4081 for further details and current cost of the street cut permit.

3. ADDITIONAL INFORMATION

Work outside the City of Dayton Corporation Limits add 10%.

A trip charge of \$200 will be made for a broken appointment when a crew arrives at a site to perform scheduled work and the Contractor has not prepared the site for the work. Work shall be ready to commence within 30 minutes upon arrival to the site. For broken trip charges, the permit holder will be invoiced.

All Sewer Repair work in the Right-of-Way shall be performed by the City billed at actual cost at the prevailing rates. Cost shall be paid in advance.

Water and sewer services installed simultaneously in any class of street where rock is encountered, the water service will be installed on a shelf adjacent to the sewer and the price per lineal foot corresponding to the type of surface will be reduced 50 percent.

WATER PERMITS

(In areas metered by the City of Dayton)

Water Service Permits (From water main to meter, fireline, backflow preventer or fire hydrant).

Except in areas metered by Montgomery County, all service taps, installations, pick-ups, or the splitting of an existing service requires a Dayton water service permit in addition to a permit from the appropriate local agency having jurisdiction over the water distribution system. Dayton permits are obtained from the Division of Building Inspections, Department of Building Services, and are issued only to licensed Plumbers/Excavators. Homeowners may obtain permits for certain work “on premises.” The Building Inspections office is located at 371 W. 2nd Street on the second floor (937-333-3892)

Relocated Meter Permit

Requires City of Dayton permit

Repair Permits

Policy varies - See Inspections for clarification.

Plumbing Permits

All work, whether new or repair, on piping after the meter, including backflow prevention and well disconnects is considered plumbing and requires a Plumbing Permit from the agency having jurisdiction.

Fire Hydrant Use Permits

Fire hydrant Permits may be obtained from the City of Dayton, One Stop Shop, at 371 West Second St (937-333-3749) and/or the local utility responsible for its operation and maintenance (Policy for use varies).

PERMIT EXAMPLES

LOCATION	TAP TO PROPERTY LINE	SERVICE (New, Pickup)	PLUMBING
Dayton (includes airport)	Dayton	Dayton	Dayton
Montgomery County	Montgomery County	Montgomery County	Montgomery County
Kettering *	Montgomery County	Montgomery County	Kettering
Riverside	Montgomery County	Montgomery County	Montgomery County
Trotwood (old)	Trotwood and Dayton	Trotwood and Dayton	Montgomery County
Trotwood (new)	Montgomery County	Montgomery County	Montgomery County
Brookville *	Brookville and Dayton	Brookville and Dayton	Montgomery County
Clayton	Clayton and Dayton	Clayton and Dayton	Montgomery County
Englewood *	Montgomery County	Montgomery County	Montgomery County
Greene County	Greene County San. Dayton	Greene County San. Dayton	Greene County

* Installation or repair from property line to foundation inspected by Village or City indicated regardless of meter location. (Permits required)

NOTE: Taps and New Services done at same time, to the meter, require one service permit only. Subsequent separate activities require a service permit for each activity, i.e.: Combination Services.

WATER AND SEWER SERVICE INSPECTIONS

Phone Numbers (Numbers are Area Code 937)

City of Dayton:

Water Engineering:	One Stop Shop	333-6804
	Inspection	333-3725
General - 320 W. Monument		333-3725
Water Distribution		333-4905
Water Meter Shop		333-4902
Fire Department		333-4520
Plumbing Inspection		333-3892

Montgomery County Water/Sanitary	781-2500
Montgomery Co. Plumbing Inspection	225-4421
Brookville	833-4866
Trotwood	837-1702

Dayton	Water Engineering	WUFO	Fire Department	Plumbing Inspection
All new water and/or sewer tap and service to property line (including curb stop on water services)		X		X
New, pickups, 1" & 1½" services curb stop to meter (5/8", ¾" & 1" meters)		X		X
New, pickups, 1½" and larger services to meter/fire backflow preventer or hydrant	X			X
Picked up water services and repairs after meter				X
Repairs on water services before meter - 5/8" to 1" meters				X
- Over 1" meters	X			X
Repairs on sewer laterals				X
Water Service Replacement, main to curb stop		X		
Water Service Replacement, after curb stop				X
Sewer Lateral – New and Replacement				X
Meter Pit (New) - 5/8" to 1" meter		X		X
- Over 1" meter	X			X
Meter Pit (Relocate & Repair) - 5/8" to 1" meters				X
- Over 1" meters	X			X
Fire Line - Before Backflow Device	X			
- After Backflow Device			X	
Backflow Preventer	X			X

WATER SERVICE INSPECTIONS – OUTSIDE CITY
(Water service work only; call Dayton’s Plumbing Inspection for sewer inspections)

Outside of Dayton City Limits (in areas metered by Dayton)	Water Engineering	WUFO	Local Water Jurisdiction	Local. Plumbing Inspection	Dayton Plumbing Inspection
All taps, 1", and services to property line (including curb stop)		X	X		X
New, pickups, 1" & 1 1/2" services curb stop to meter (5/8", 3/4" & 1" meters)		X			X
New, pickups, 1 1/2" meter and larger services main to meter/fire backflow preventer or hydrant	X		X		X
Picked up services and repairs after meter				X	X
Repairs on services before meter - 5/8" to 1" meters			X		X
- Over 1" meters	X		X		X
Service Replacement, main to curb stop			X		X
Service Replacement - after curb stop			X		X
Meter Pit (New) - 5/8" to 1" meters		X	X		X
- Over 1" meters	X		X		X
Meter Pit (Relocate & Repair) - 5/8" to 1" meters			X		X
- Over 1" meters	X		X		X
Plumbing (after meter)				X	
Backflow Preventer (at meter)			X		
Backflow Preventer (in building, not at meter)				X	
Properties with wells			X	X	X

Montgomery County

In areas metered by the Montgomery County Environmental Service’s office, consult their office to determine inspection responsibilities. Neither Dayton’s Water Engineering nor Water Utility Field Operation performs inspections in these areas.

TESTING FOR LEAKAGE/PRESSURE AND PURITY

General

All new, picked up or repaired services shall be tested for leakage and purity as outlined in the City of Dayton Department of Water “Rules and Regulations Governing Plumbers and Excavators”.

Pressure/Leakage Test

New services for fire and/or domestic use shall be tested. During the test no leakage shall be allowed on exposed joints. Test specifications for domestic services are as follows:

TYPE OF SERVICE	MAIN TO PROPERTY LINE	PL TO BUILDING
K-copper (domestic)	Line Pressure	150 psi. Or 1.5 times the working pressure, whichever is greater.
Ductile Iron (domestic)	Tested to tap valve at 150 psi. or 1.5 times the working pressure, whichever is greater	
Ductile Iron (fireline before double-check valve)	Same as Ductile Iron (domestic)	
Fire line after Double-check Valve	Tested at 200 psi. If subject to pressurization by Fire Department pumps.	

The duration of the pressure/leakage test shall be as required to ascertain a leak-free service as deemed necessary by the inspecting agency.

For fire service testing, the testing requirements of the current edition of NFPA #24 shall apply. Following satisfactory completion of the hydrostatic test, the line must be flushed also in accordance with NFPA #24. The Contractor shall provide the Fire Department with a completed “Contractor’s Material and Test Certificate for Underground Piping.”

Disinfection

Purity tests are required on all underground piping installed in rigid lengths. New copper pipe from a sealed coil shall be thoroughly flushed prior to use for either fire or domestic use. The required test may be performed by the Department of Water as part of service work done by the City. Two consecutive purity tests, 24 hours apart, shall be taken at the metering location or fire line double-check valve or hydrant as appropriate, in accordance with Ohio EPA directives and AWWA procedure. Purity tests beyond the purveyor's jurisdiction shall be required as needed by Plumbing Inspection of the local jurisdiction. Chlorine dosages shall meet or exceed applicable AWWA standards.

For purposes of filling the new pipe or collecting purity samples, a service or mainline valve may be temporarily opened only while under the continuous supervision of a representative of the local water purveyor. **UNATTENDED GARDEN HOSE FLUSHES ARE PROHIBITED.**

WATER AND SEWER SERVICES – ADDITIONAL NOTES

1. Meter pits are generally mandatory for all domestic/irrigation meters. Meter installations may be allowed inside of buildings only when there is no location outside of the building for a pit on the customer's property. Contact Water Engineering for approval of such situations.
2. Restrained joints for ductile iron pipe
 - Acceptable – Megalugs at all fittings and valves; and field lock gaskets at push on bells
 - Not acceptable – Restraining rods
3. Deduct meter piping arrangements are prohibited.
4. Sanitary sewer laterals are considered private and not marked by OUPS.
5. 4" and Larger water services, the piping material must be ductile iron pipe through the meter pit. After the meter pit, the piping material may be as accepted by local and national plumbing and fire codes. Any transitions to other materials should occur a minimum of 3 feet on the customer's side of the meter pit.
6. 1" through 2" water services, Type K-copper pipe must be used through the meter. After the meter, the piping material must meet the State plumbing code. When the pipe materials change, the transition should occur a minimum of 3 feet on the customer side of the meter pit. A restrained type of pack joint such as the Ford Meter Box "Brass Grip Coupling" Joint or approved equal should be used.
7. Curb stops are to be located at the Right-of-Way/Property line or water easement line (typically adjacent to the back of the sidewalk). Curb stops should not be located to the far side of other utility easements.
8. When a new containment backflow prevention device is being installed on an existing service, the meter-spread piping must be brought up to current standards.
9. Two concepts are acceptable for combination services with the meter located in a pit. One configuration would include the domestic metering and the fire line double detector check both in a large vault. All the clearance criteria and material specifications from the following large pit details apply. In addition, note the following:
 - An outlet tee must be provided for the domestic branch. Tapping of the pipe is not permitted within the pit.
 - When a 1" or smaller domestic or irrigation meter is proposed that meter must be installed in a Ford Box adjacent to the large pit. No curb stop is required.

The second acceptable concept would be to install an underground tee in the combined service piping, install a pit only on the domestic and irrigation water meters, and continue the fire line into the building where the double-detector check would be located. In such configurations, sufficient valving must be provided to avoid depressurizing the service after the initial pressure and purity and pressure tests are performed. When different contractors are installing the domestic and fire legs of the combined service, an isolation valve and plug must be installed on the opposite leg of the service at the location of the tee before pressure and purity tests can be performed.

1" SERVICE (5/8" , 3/4" or 1 " Meter)

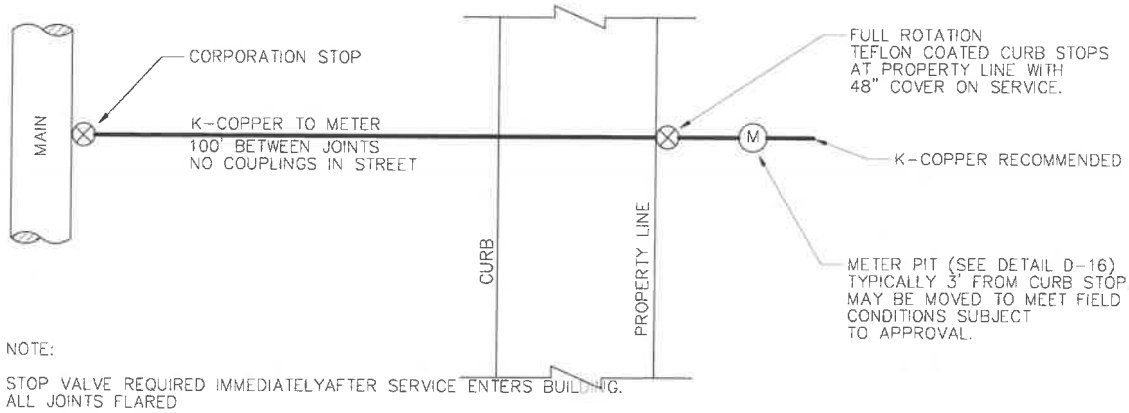

1 1/2" SERVICE (1" Meter)

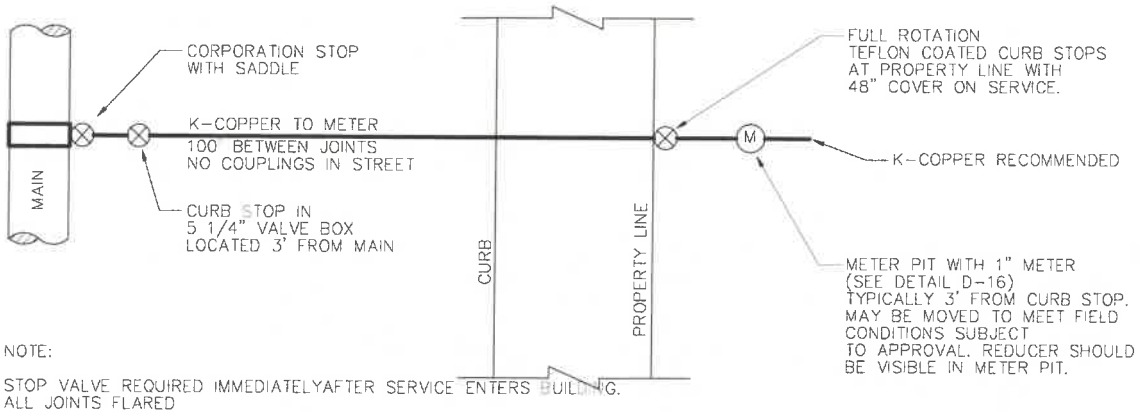

GENERAL NOTE:
CONTACT WATER ENGINEERING FOR ANY
SITUATION NOT COVERED IN STANDARDS

N.	DATE	REVISIONS
1	2/07	CURB STOP
2	3/07	NOTES
3	7/19	NOTES

TYPICAL SERVICE
INSTALLATION

STANDARD DRAWING
DEPT. OF WATER ENGINEERING
CITY OF DAYTON

SCALE: NOT TO SCALE
DRAWN: 07-1999 BY: JBS

1 1/2" SERVICE (1 1/2" Meter)

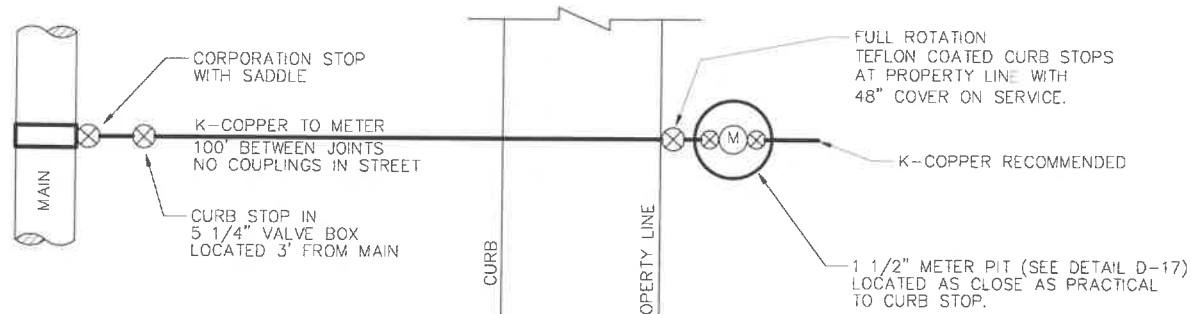

NOTE:

STOP VALVE REQUIRED IMMEDIATELY AFTER SERVICE ENTERS BUILDING.
ALL JOINTS FLARED

2" SERVICE (1 1/2" or 2" Meter)

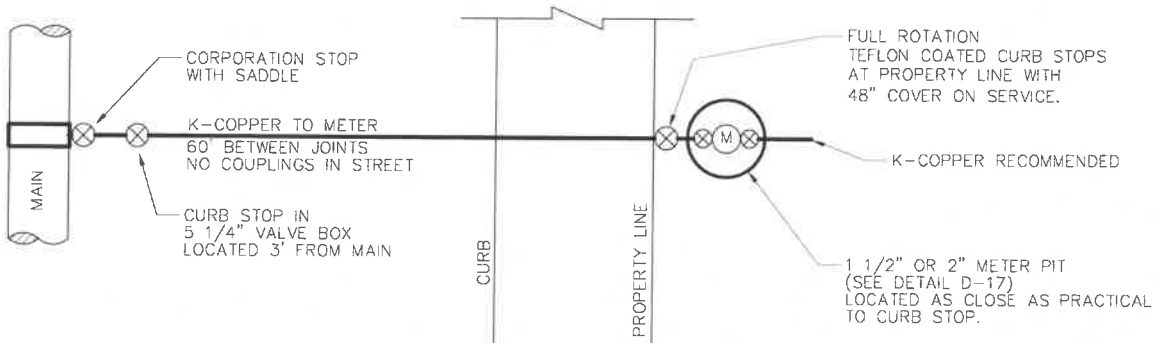

NOTE:

STOP VALVE REQUIRED IMMEDIATELY AFTER SERVICE ENTERS BUILDING.
ALL JOINTS FLARED

GENERAL NOTE:
CONTACT WATER ENGINEERING FOR ANY
SITUATION NOT COVERED IN STANDARDS

NO.	DATE	REVISIONS
1	2/07	CURB STOP
2	3/07	NOTES
3	7/19	NOTES

TYPICAL SERVICE
INSTALLATION

STANDARD DRAWING
DEPT. OF WATER ENGINEERING
CITY OF DAYTON

SCALE: NOT TO SCALE
DRAWN: 07-1989 BY: JBS

SPLIT SERVICE

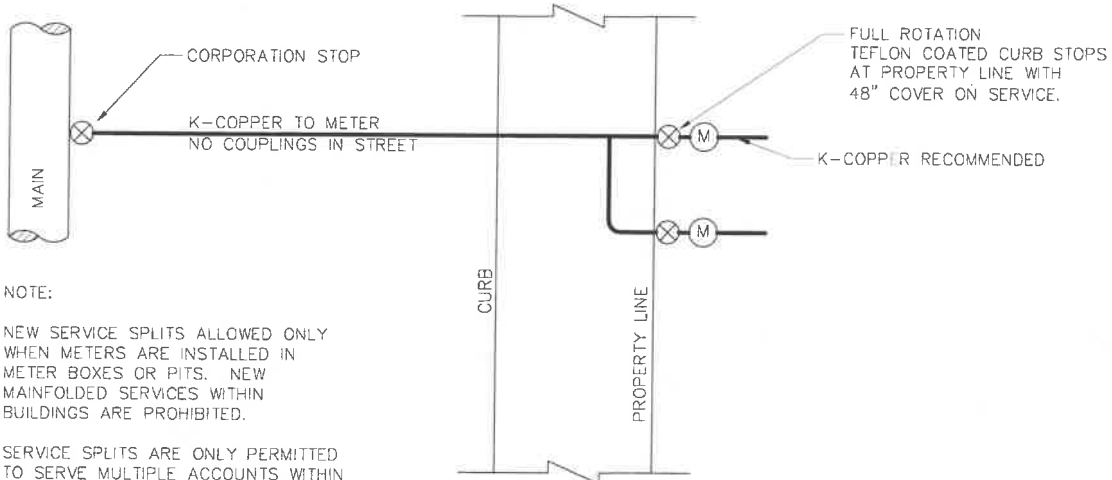

NOTE:

1. NEW SERVICE SPLITS ALLOWED ONLY WHEN METERS ARE INSTALLED IN METER BOXES OR PITS. NEW MAINFOLDED SERVICES WITHIN BUILDINGS ARE PROHIBITED.
2. SERVICE SPLITS ARE ONLY PERMITTED TO SERVE MULTIPLE ACCOUNTS WITHIN A SINGLE BUILDING ON ONE PROPERTY.
3. ALL JOINTS FLARED
4. CURB STOP SHOULD BE INSTALLED ON PERPENDICULAR LINE FROM MAIN

4" AND LARGER SERVICE (Domestic)

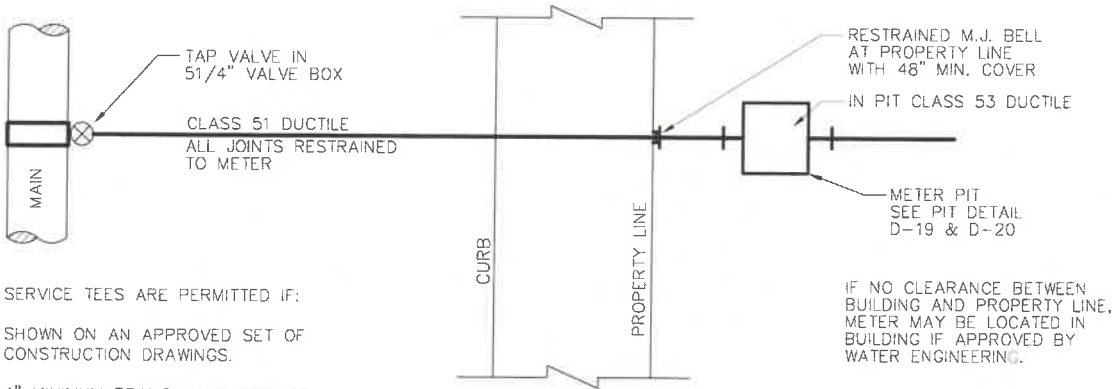

SERVICE TEES ARE PERMITTED IF:

1. SHOWN ON AN APPROVED SET OF CONSTRUCTION DRAWINGS.
2. 4" MINIMUM BRANCH AND SERVICE LINE WITH GATE VALVE WITHIN 3' OF THE MAIN.
3. STUB IN PERMITS MUST BE OBTAINED FOR EACH SERVICE STUBBED INTO PROPERTY LINE OR EASEMENT LINE.

GENERAL NOTE:
CONTACT WATER ENGINEERING FOR ANY SITUATION NOT COVERED IN STANDARDS

NO.	DATE	REVISIONS
1	2/07	CS, MP.
2	3/07	NOTES
3	6/19	NOTES

TYPICAL SERVICE INSTALLATION

STANDARD DRAWING
DEPT. OF WATER ENGINEERING
CITY OF DAYTON

SCALE: NOT TO SCALE
DRAWN: 07-1999 BY: JBS

2" FIRE LINE (Detector Meter Not Required)

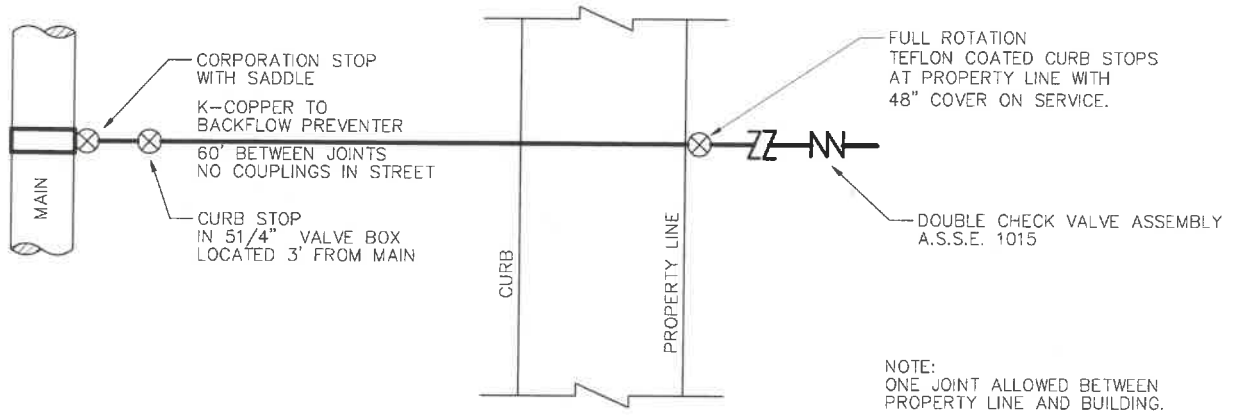

4" AND LARGER FIRE LINE

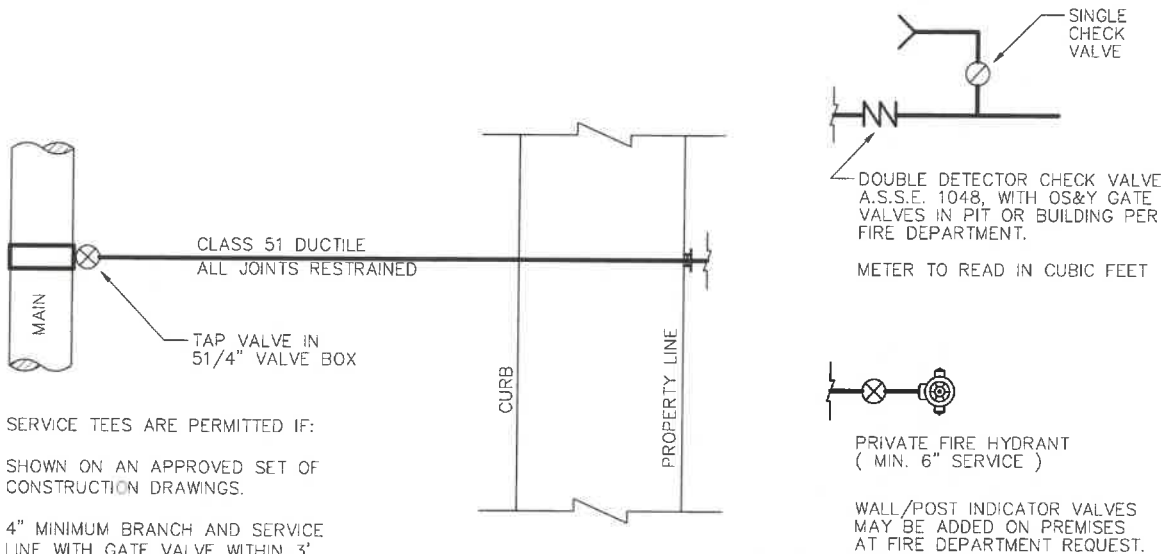

SERVICE TEES ARE PERMITTED IF:

1. SHOWN ON AN APPROVED SET OF CONSTRUCTION DRAWINGS.
2. 4" MINIMUM BRANCH AND SERVICE LINE WITH GATE VALVE WITHIN 3' OF THE MAIN.
3. STUB IN PERMITS MUST BE OBTAINED FOR EACH SERVICE STUBBED INTO PROPERTY LINE OR EASEMENT LINE.

GENERAL NOTE:
CONTACT WATER ENGINEERING FOR ANY SITUATION NOT COVERED IN STANDARDS

NO.	DATE	REVISIONS
1	2/07	CURB STOP
2	3/07	NOTES
3	6/19	NOTES

TYPICAL SERVICE INSTALLATION

STANDARD DRAWING
DEPT. OF WATER ENGINEERING
CITY OF DAYTON

SCALE: NOT TO SCALE
DRAWN: 07-1999 BY: JBS

4" AND LARGER COMBINATION SERVICE FIRE LINE WITH BACKFLOW INSIDE BUILDING

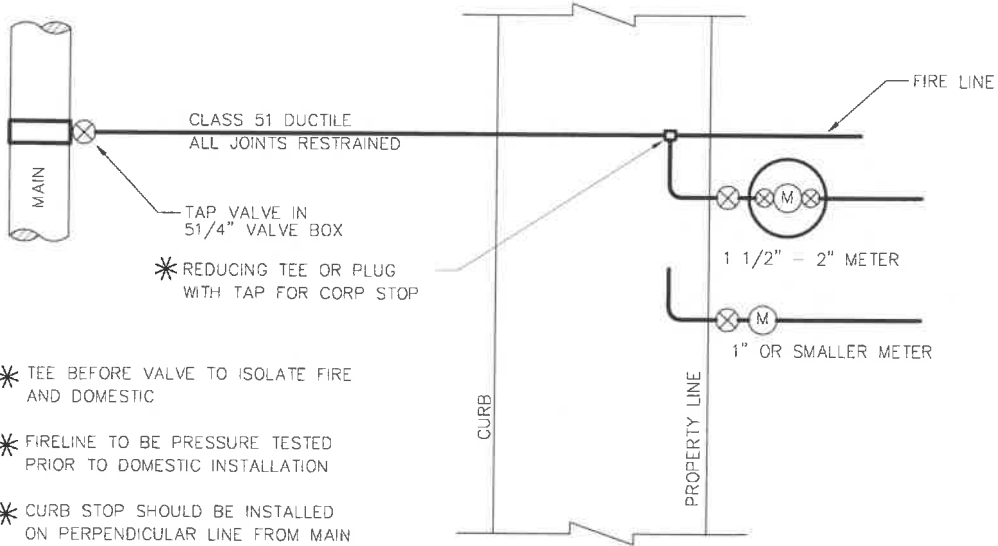

GENERAL NOTE:
CONTACT WATER ENGINEERING FOR ANY
SITUATION NOT COVERED IN STANDARDS

N.	DATE	REVISIONS
1	3/07	NOTES

TYPICAL SERVICE INSTALLATION

STANDARD DRAWING
DEPT. OF WATER ENGINEERING
CITY OF DAYTON

SCALE: NOT TO SCALE
DRAWN: 02-2007 BY: JBS

3/4" OR 1" SINGLE SERVICE REPLACEMENT ON PROPERTY

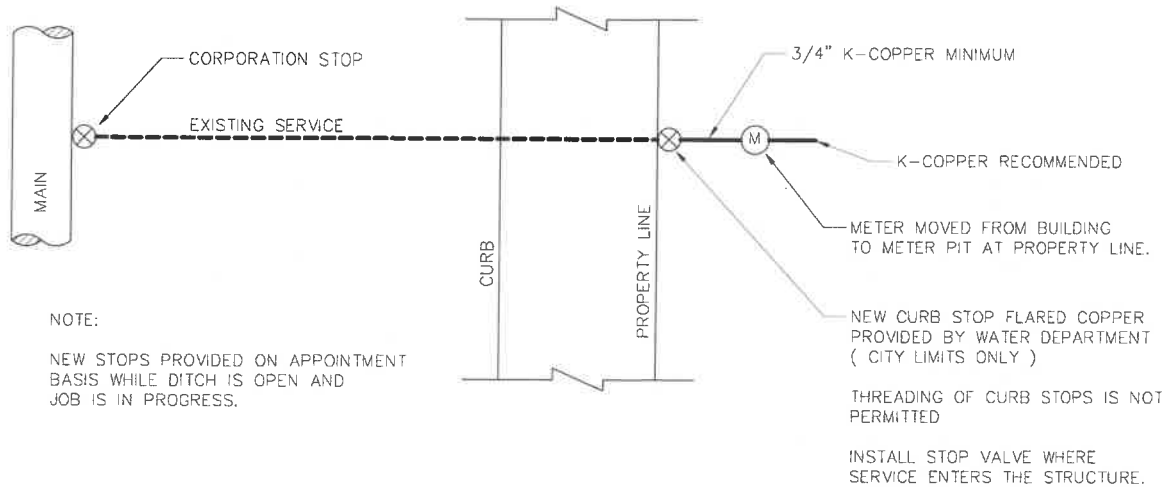

3/4" OR 1" SINGLE SERVICE REPLACEMENT FROM MAIN TO BUILDING

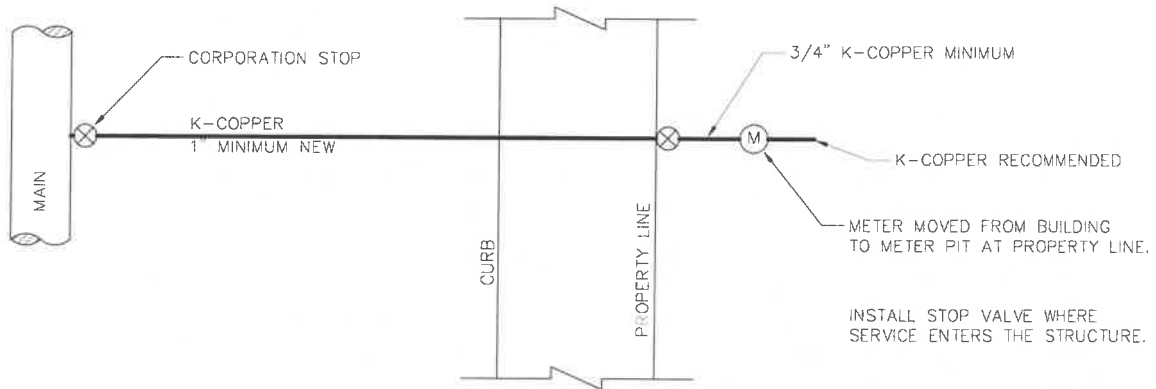

GENERAL NOTE:
CONTACT WATER ENGINEERING FOR SERVICE REPLACEMENT ON 1 1/2" OR LARGER.

NO.	DATE	REVISIONS

TYPICAL SERVICE REPLACEMENT

STANDARD DRAWING
DEPT. OF WATER ENGINEERING
CITY OF DAYTON

SCALE: NOT TO SCALE
DRAWN: 07-1999 BY: JBS

1/2" TO 1 1/2" SERVICE REPAIR

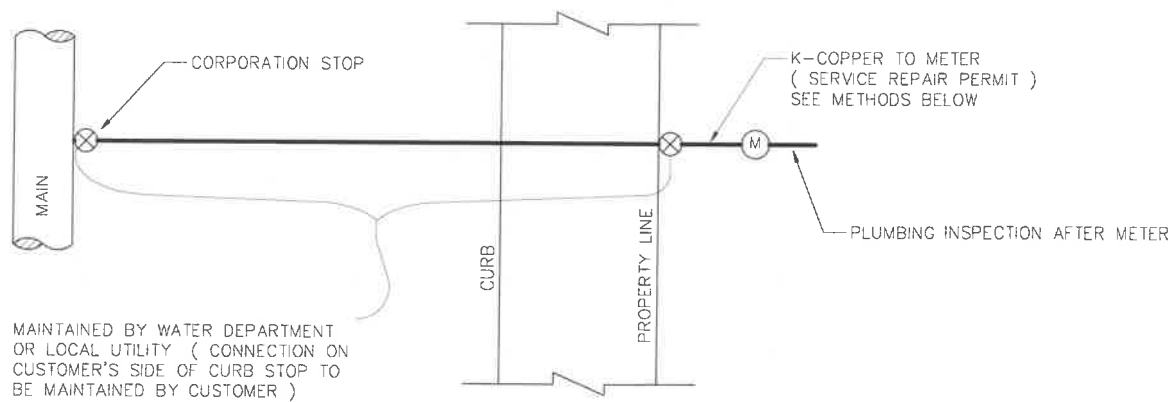

MAINTAINED BY WATER DEPARTMENT OR LOCAL UTILITY (CONNECTION ON CUSTOMER'S SIDE OF CURB STOP TO BE MAINTAINED BY CUSTOMER)

NOTE: REPAIR ALLOWED ON COPPER ONLY

REPAIR OF GALVANIZED OR LEAD IS NOT PERMITTED AND REQUIRE A SERVICE REPLACEMENT, WITH METER PIT INSTALLATION.

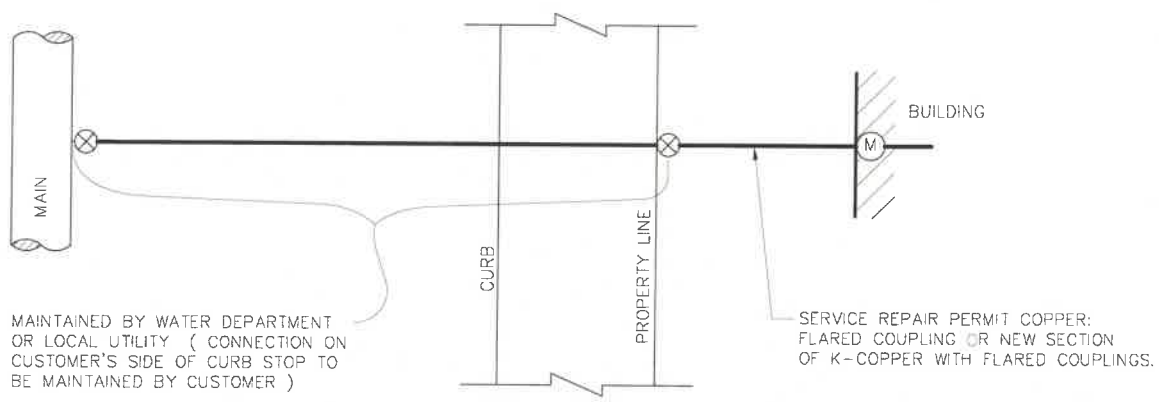

MAINTAINED BY WATER DEPARTMENT OR LOCAL UTILITY (CONNECTION ON CUSTOMER'S SIDE OF CURB STOP TO BE MAINTAINED BY CUSTOMER)

SERVICE REPAIR PERMIT COPPER: FLARED COUPLING OR NEW SECTION OF K-COPPER WITH FLARED COUPLINGS.

GENERAL NOTE:
CONTACT WATER ENGINEERING FOR ANY SITUATION NOT COVERED IN STANDARDS

NO.	DATE	REVISIONS
1	2/07	CURB STOPS

TYPICAL SERVICE REPAIR

STANDARD DRAWING
DEPT. OF WATER ENGINEERING
CITY OF DAYTON

SCALE: NOT TO SCALE
DRAWN: 07-1999 BY: JBS

2" SERVICE REPAIR

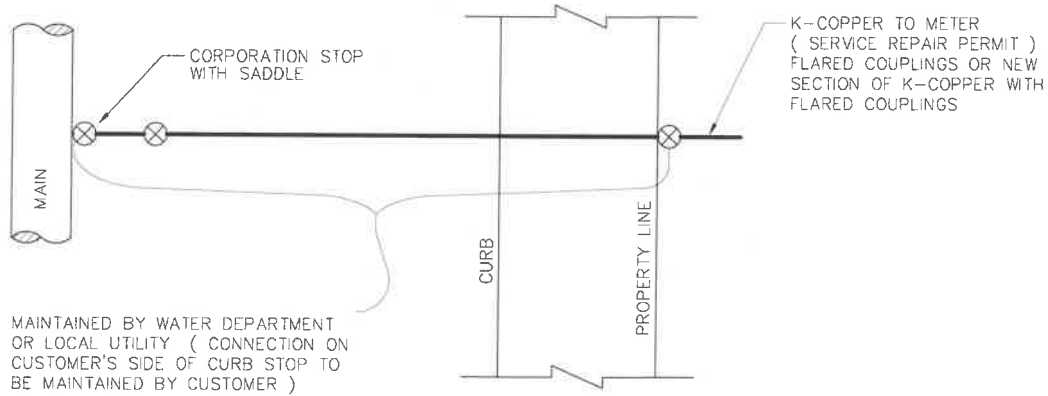

3" AND LARGER SERVICE REPAIR

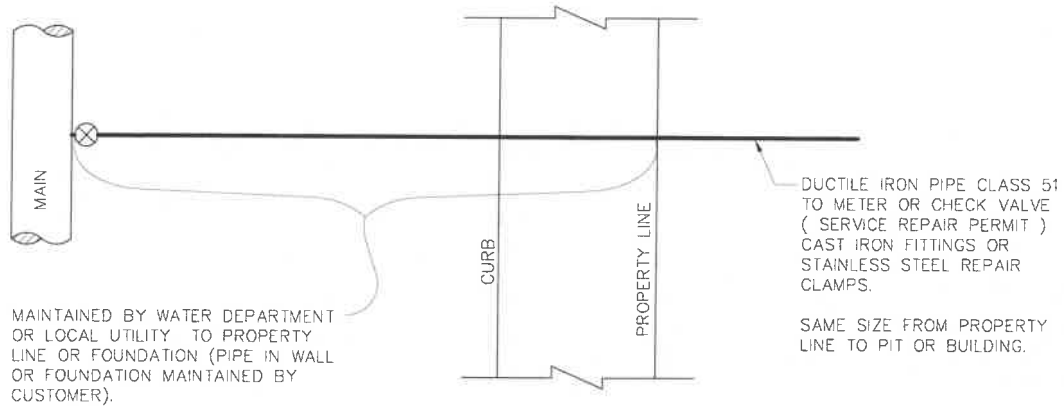

GENERAL NOTE:
CONTACT WATER ENGINEERING FOR ANY SITUATION NOT COVERED IN STANDARDS

N.	DATE	REVISIONS
1	2/07	CURB STOP
2	7/19	NOTES

TYPICAL SERVICE REPAIR

STANDARD DRAWING
DEPT. OF WATER ENGINEERING
CITY OF DAYTON

SCALE: NOT TO SCALE
DRAWN: 07-1999 BY: JBS

5/8", 3/4" AND 1" WATER METER STANDARD INSTALLATION

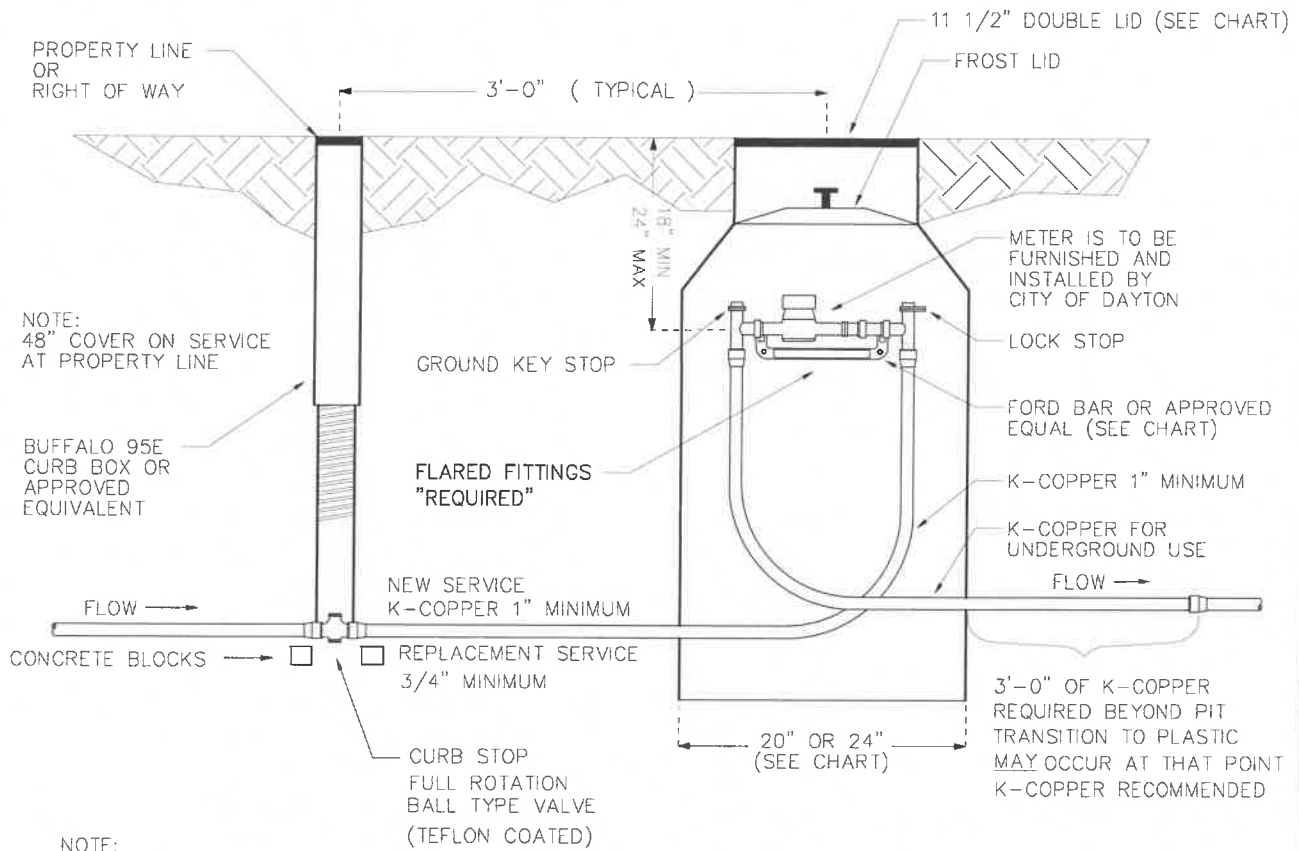

1. TILE MADE OF CONCRETE OR VITRIFIED CLAY. ALTERNATE HIGH DENSITY POLYETHELENE METER BOXES, SUCH AS MS 20x30 OR MS 24x30 AS MANUFACTURED BY MID STATES PLASTICS OR APPROVED EQUAL, MAY BE USED FOR INSTALLATIONS NOT SUBJECTED TO MOTOR VEHICLE LOADS.
2. IF A 1 1/2" SERVICE IS USED, THEN THE 1 1/2" TO 1" REDUCTION MUST BE AT THE YOKE.
3. DUAL METER CONFIGURATIONS-2@5/8" METERS MAY BE INSTALLED IN A 24" PIT
4. METER PIT LID MUST BE @ FINAL GRADE BEFORE METER SET
5. METER PITS TO BE LOCATED OUTSIDE SIDEWALKS & DRIVEWAYS

FORD CATALOG YOKE NUMBER	SERVICE PIPE SIZE	METER SIZE	EQUIVALENT METER SPREAD	TILE SIZE	TOP SECTION	LID
517 (501 BAR)	1"	5/8"	7 1/2"	20"	W3	W3-T
517 (501 BAR)	1"	5/8" x 2	11 1/2"	24"	W3	W3-TT
519 (503 BAR)	1"	3/4"	13 1/2"	20"	W3	W3-T
520 (504 BAR)	1" OR 1 1/2"	1"	15 1/2"	24"	W3 & #2 RING	W3-T

*** NOTE: NO 502 BARS ***

GENERAL NOTE:
CONTACT WATER ENGINEERING FOR ANY SITUATION NOT COVERED IN STANDARDS

NO.	DATE	REVISIONS
1	3/20	NOTES

WATER METER INSTALLATION

STANDARD DRAWING
DEPT. OF WATER ENGINEERING
CITY OF DAYTON

SCALE: NOT TO SCALE
DRAWN: 07-1999 BY: JBS

1 1/2" AND 2" WATER METER PIT STANDARD INSTALLATION (FOR OFF ROAD USE ONLY)

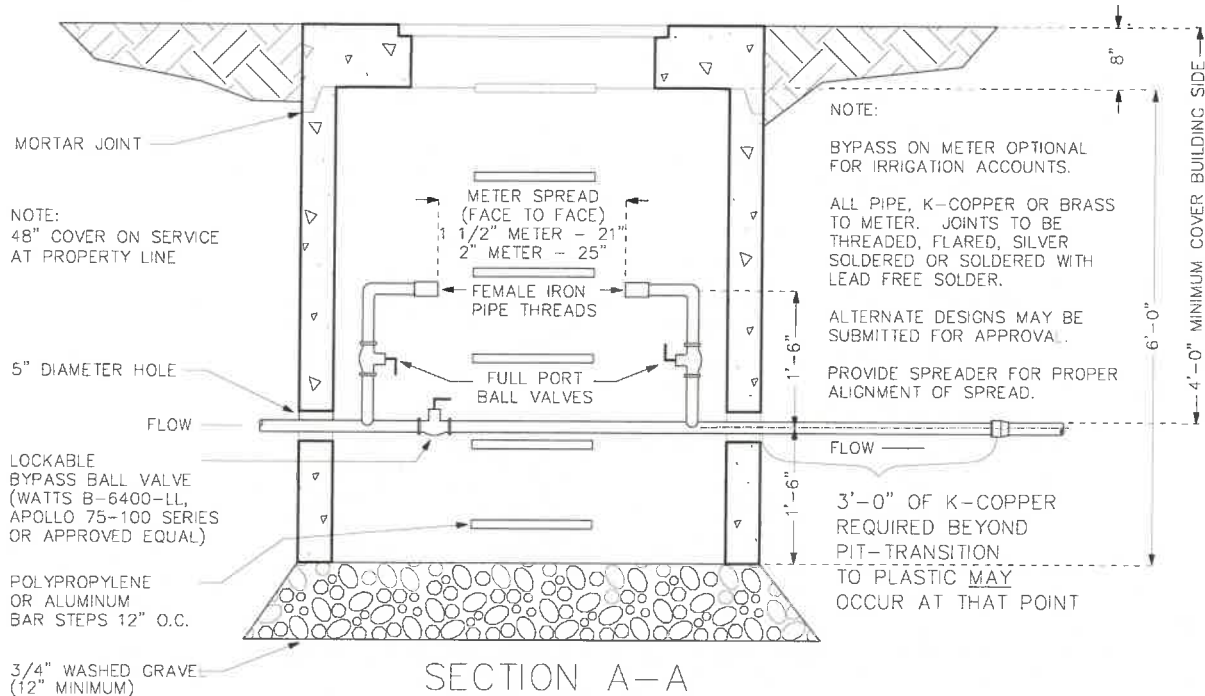
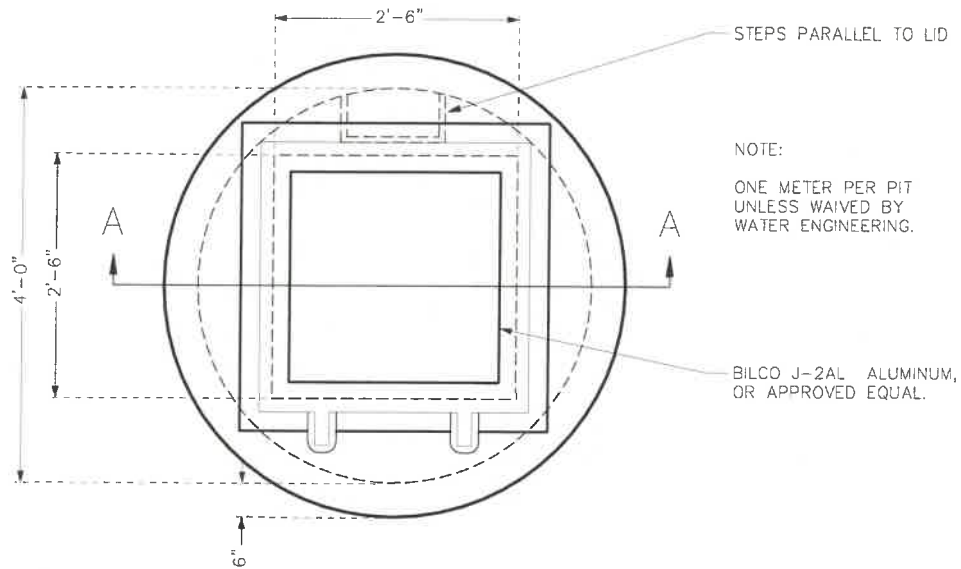

GENERAL NOTE:
CONTACT WATER ENGINEERING FOR ANY
SITUATION NOT COVERED IN STANDARDS

NO.	DATE	REVISIONS
1	12/00	1AL TO 2AL
2	12/00	1 1/2" Spread
3	3/07	BALL VALVE
4	7/19	NOTES

WATER METER PIT INSTALLATION

STANDARD DRAWING
DEPT. OF WATER ENGINEERING
CITY OF DAYTON

SCALE: NOT TO SCALE
DRAWN: 07-1999 BY: JBS

LARGE METER LAYOUT IN BUILDING

1 1/2" & 2" SERVICES:

COPPER PIPING THROUGH BACKFLOW
DEVICE IS RECOMMENDED.

4" AND GREATER SERVICES:

PIPING SHALL BE D.I.P. CLASS 53
TO RIGID FLANG, FROM RIGID FLANGE
THROUGH METER VALVES & BYPASS
TO BE DUCTILE, COPPER OR BRASS.

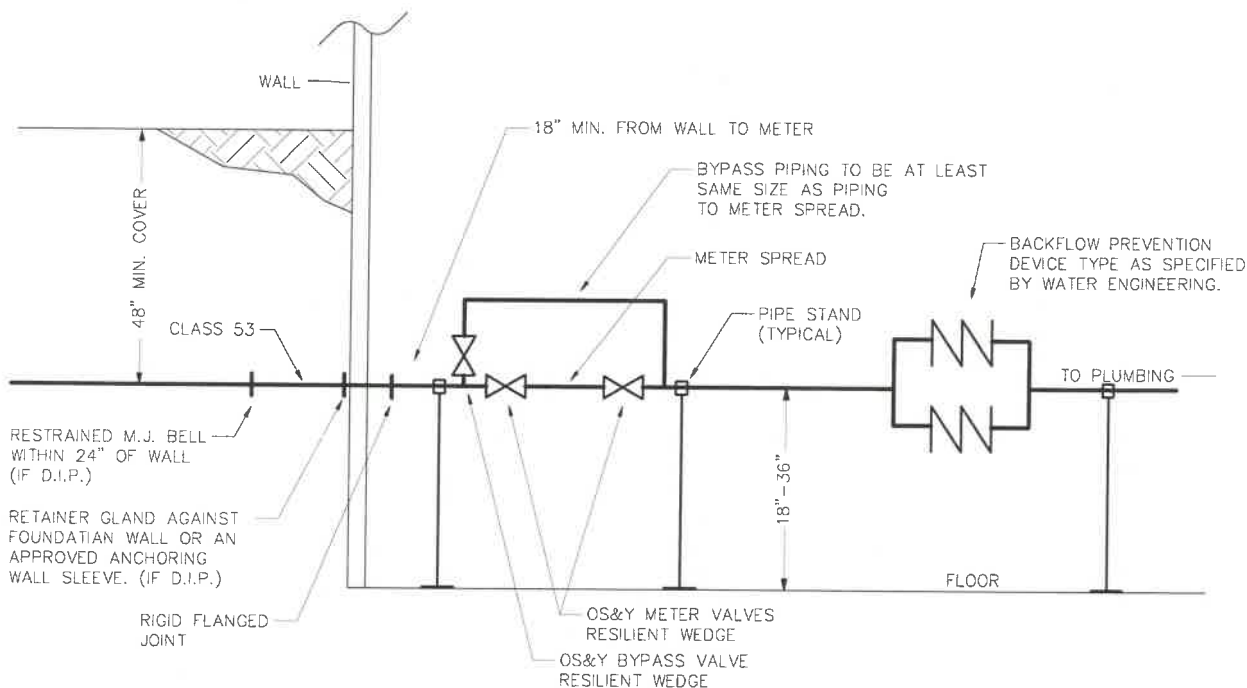

NOTE:

1. FULL PORT BALL VALVES IN LIEU OF OS&Y VALVES MAY BE INSTALLED FOR 1 1/2" & 2" METERS.
2. BYPASS MANDATORY FOR ALL METERS. BYPASS VALVE MUST BE LOCKABLE.
3. DUAL INSTALLATION FOR BACKFLOW PREVENTION DEVICES IS OPTIONAL FOR IRRIGATION SERVICES.
4. ALTERNATE DESIGNS MAY BE SUBMITTED TO WATER ENGINEERING FOR APPROVAL.
5. PROVIDE SPREADER FOR PROPER ALIGNMENT ON INSTALLATION OF METER SPREAD.
6. NO FLANGE ADAPTERS BEFORE INITIAL SHUT-OFF VALVE(S).
7. PROVIDE 1/2" CONDUIT WITH PULL STRING TO OUTSIDE OF BUILDING FOR REMOTE READ WIRING
8. FLOOR DRAIN IS REQUIRED IN ROOM WHERE METER AND BACKFLOW DEVICES ARE LOCATED.

METER SPREAD (FACE TO FACE)

SERVICE SIZE	METER SPREAD	REMARKS
1 1/2"	21"	F.I.P.
2"	25"	F.I.P.
3"	46"	FLANGED
4"	56"	FLANGED
6"	60"	FLANGED
8" & LARGER	TO BE REVIEWED BY DISTRIBUTION/ENGINEERING	

GENERAL NOTE:
CONTACT WATER ENGINEERING FOR ANY
SITUATION NOT COVERED IN STANDARDS

NO.	DATE	REVISIONS
1	3/01	1 1/2" Spread
2	3/07	18" NOTE
3	7/19	NOTES

METER LAYOUT
IN BUILDING
STANDARD DRAWING
DEPT. OF WATER ENGINEERING
CITY OF DAYTON
SCALE: NOT TO SCALE
DRAWN: 07-1999 BY: JBS

COMBINATION FIRE & DOMESTIC METER LAYOUT IN BUILDING

NOTE:

COMBINATION SERVICE ONLY PERMITTED INSIDE BUILDING IF THERE IS NO LOCATION OUTSIDE OF THE BUILDING FOR A PIT ON THE CUSTOMER'S PROPERTY

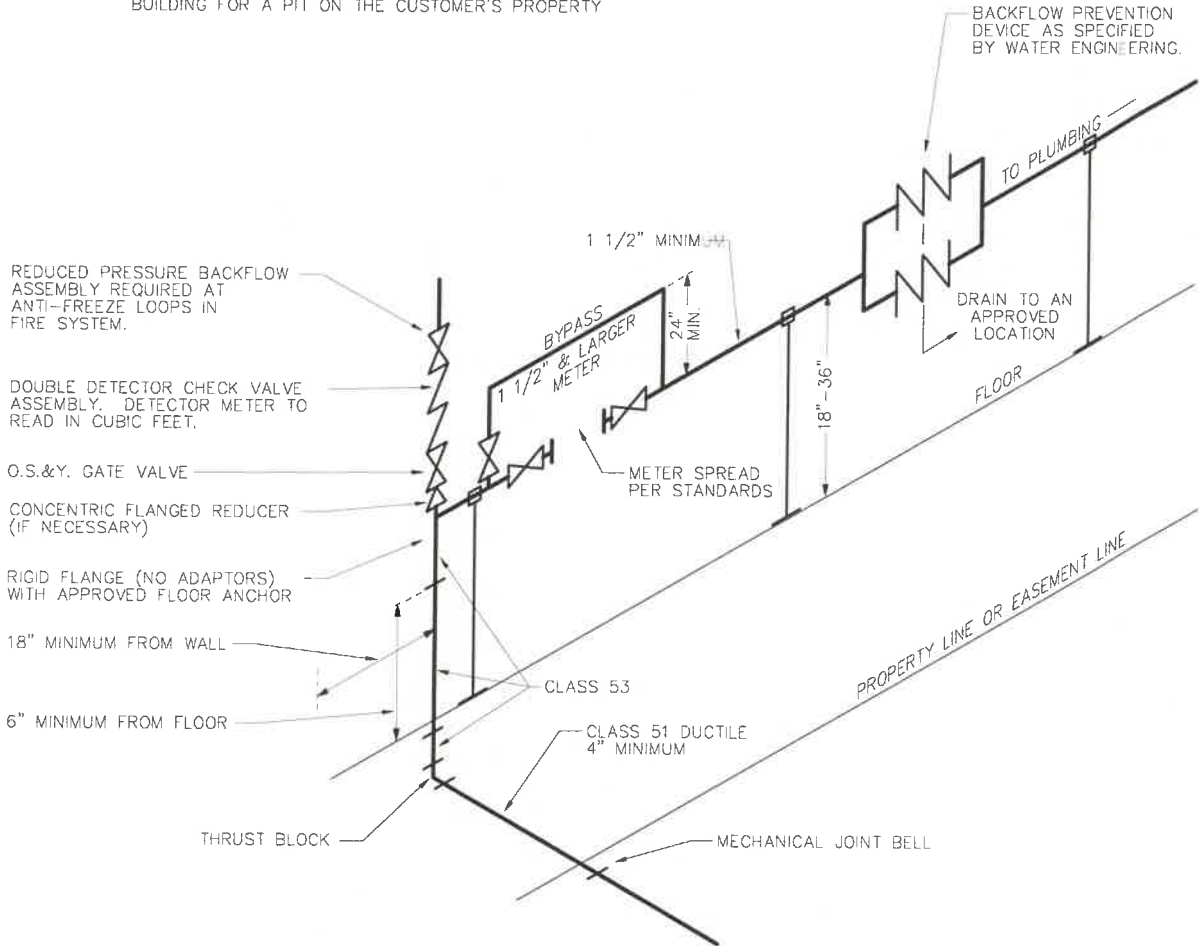

NOTE:

1. ALL UNDERGROUND JOINTS MUST BE RESTRAINED.
2. INSIDE PIPING SHALL BE D.I.P. CLASS 53 TO RIGID FLANGE. FROM RIGID FLANGE THROUGH METER VALVES AND BYPASS TO BE D.I.P. ,K-COPPER OR BRASS.
3. ALTERNATE DESIGN MAY BE SUBMITTED TO WATER ENGINEERING FOR APPROVAL.
4. FLOOR DRAIN IS REQUIRED IN ROOM WHERE METER & BACKFLOW PREVENTER ARE LOCATED
5. PROVIDE SPREADER FOR PROPER ALIGNMENT ON INSTALLATION OF METER SPREAD.
6. ADJACENT WALL CLEARANCE - 18" MINIMUM
7. PROVIDE 1/2" CONDUIT WITH PULL STRING TO OUTSIDE OF BUILDING FOR REMOTE READ WIRING

GENERAL NOTE:
CONTACT WATER ENGINEERING FOR ANY SITUATION NOT COVERED IN STANDARDS

NO.	DATE	REVISIONS
1	7/19	NOTES

METER LAYOUT IN BUILDING
STANDARD DRAWING
DEPT. OF WATER ENGINEERING
CITY OF DAYTON
SCALE: NOT TO SCALE
DRAWN: 07-1989 BY: JBS

3" & 4" METER PIT INSTALLATION (FOR OFF ROAD USE ONLY)

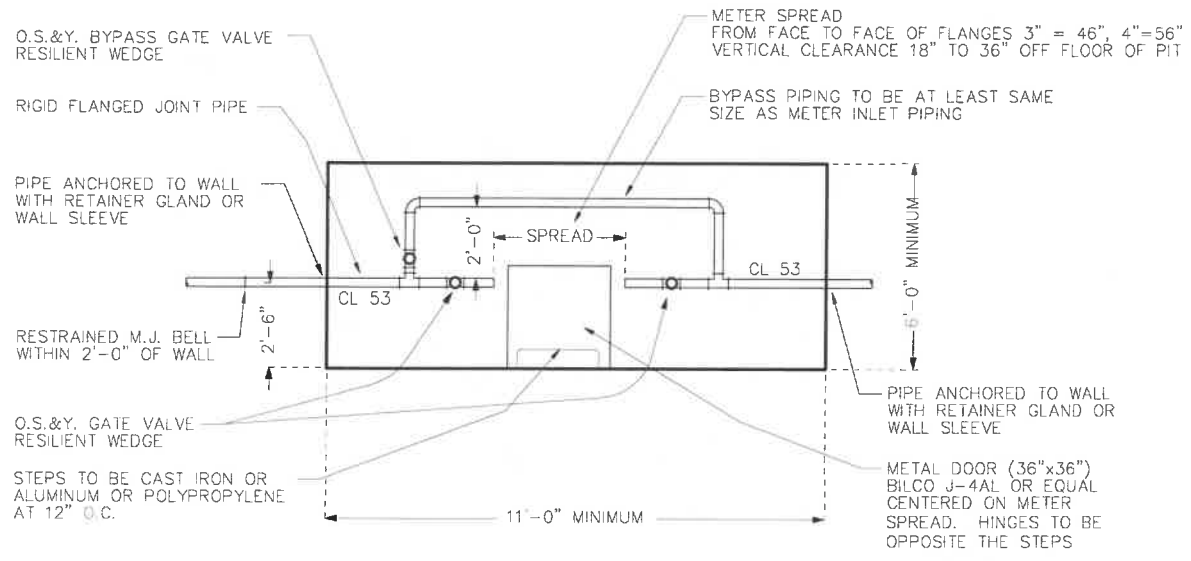

NOTE:

1. DIMENSIONS SHOWN ARE INSIDE MEASUREMENTS OF PIT.
2. ALL PIPE SHALL BE CLASS 53 DUCTILE WITH FLANGED ENDS. (COPPER & BRASS MAY BE ACCEPTABLE. **SUBMIT FOR APPROVAL**.)
3. ALL VALVES SHALL BE FLANGED END, HANDWHEEL OPERATED, O.S.&Y. GATE VALVES, RESILIENT WEDGE.
4. PIT SHALL HAVE AN INSIDE HEIGHT OF 6' MINIMUM, FROM TOP OF GRAVEL OR FLOOR.
5. PROVIDE SPREADER FOR PROPER ALIGNMENT ON INSTALLATION OF METER SPREAD. WALLS TO BE FORMED IN-PLACE OR PRECAST CONCRETE.
6. WALLS TO BE FORMED IN-PLACE OR PRECAST CONCRETE.
7. TOP SLAB TO BE DESIGNED BY REGISTERED ENGINEER OR ARCHITECT AND APPROVED BY WATER ENGINEERING.
8. 12" MINIMUM 3/4" WASHED GRAVEL IN BOTTOM OF PIT OR CONCRETE SLAB WITH SUMP HOLE.
9. PIPING AND METER SHALL BE SUPPORTED AS APPROVED BY THE ENGINEER, AND WATER DISTRIBUTION.
10. ALTERNATE DESIGN MAY BE SUBMITTED FOR APPROVAL.
11. CLEARANCE MUST BE PROVIDED FOR COMBINATION SERVICES IN PIT INSTALLATIONS. **SUBMIT FOR APPROVAL**.

GENERAL NOTE:
CONTACT WATER ENGINEERING FOR ANY
SITUATION NOT COVERED IN STANDARDS

NO.	DATE	REVISIONS
1	3/07	NOTES
2	6/19	NOTES
3	7/19	NOTES

METER LAYOUT
INSTALLATION

STANDARD DRAWING
DEPT. OF WATER ENGINEERING
CITY OF DAYTON

SCALE: NOT TO SCALE
DRAWN: 07-1999 BY: JBS

6" & LARGER METER PIT INSTALLATION (FOR OFF ROAD USE ONLY)

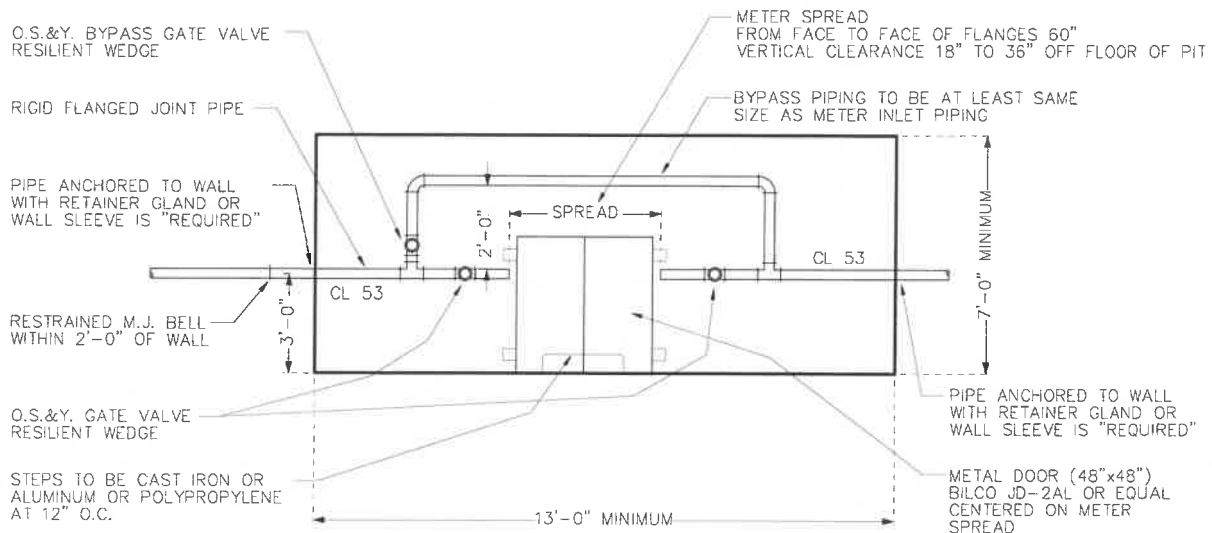

NOTES:

1. DIMENSIONS SHOWN ARE INSIDE MEASUREMENTS OF PIT.
2. ALL PIPE SHALL BE CLASS 53 DUCTILE WITH FLANGED ENDS.
3. ALL VALVES SHALL BE FLANGED END, HANDWHEEL OPERATED, O.S.&Y. GATE VALVES, RESILIENT WEDGE.
4. PIT SHALL HAVE AN INSIDE HEIGHT OF 6' MINIMUM, FROM TOP OF GRAVEL OR FLOOR.
5. PROVIDE SPREADER FOR PROPER ALIGNMENT ON INSTALLATION OF METER SPREAD.
6. WALLS TO BE FORMED IN-PLACE OR PRECAST CONCRETE.
7. TOP SLAB TO BE DESIGNED BY REGISTERED ENGINEER OR ARCHITECT AND APPROVED BY WATER ENGINEERING.
8. 12" MINIMUM 3/4" WASHED GRAVEL IN BOTTOM OF PIT OR CONCRETE SLAB WITH SLUMP HOLE.
9. PIPING AND METER SHALL BE SUPPORTED AS APPROVED BY THE ENGINEER, AND WATER DISTRIBUTION.
10. ALTERNATE DESIGN MAY BE SUBMITTED FOR APPROVAL.
11. CLEARANCE MUST BE PROVIDED FOR COMBINATION SEVICES IN PIT INSTALLATIONS. SUBMIT FOR APPROVAL

GENERAL NOTE:
CONTACT WATER ENGINEERING FOR ANY
SITUATION NOT COVERED IN STANDARDS

NO.	DATE	REVISIONS
1	3/07	NOTES
2	6/19	NOTES
3	7/19	NOTES

METER LAYOUT
INSTALLATION

STANDARD DRAWING
DEPT. OF WATER ENGINEERING
CITY OF DAYTON

SCALE: NOT TO SCALE
DRAWN: 07-1999 BY: JBS

DOUBLE DETECTOR CHECK VALVE ON NEW FIRE LINE

NOTE:

ALL BACKFLOW PREVENTION ASSEMBLIES SHALL BE DELIVERED FOR INSTALLATION COMPLETELY ASSEMBLED BY THE ORIGINAL MANUFACTURER WITH ALL COMPONENTS AS APPROVED.

NOTE:

ADDITION OF BACKFLOW DEVICE ONTO EXISTING FIRE SUPPRESSION SYSTEMS WILL AFFECT ORIGINAL FLOW CALCULATIONS.

RIGID FLANGE NO ADAPTORS
6" MIN. FROM WALL OR FLOOR

ANCHOR TO WALL OR SLAB

SUPPLY

THRUST BLOCK

A.S.S.E. 1048 DOUBLE DETECTOR CHECK VALVE WITH APPROVED INDICATING VALVES. DETECTOR METER TO READ IN CUBIC FEET.

CLASS 53 DUCTILE IRON TO VALVE
ALL JOINTS RESTRAINED.

TO FIRE SYSTEM

DOUBLE DETECTOR CHECK VALVE WITH FIRE PUMP ON NEW FIRE LINE

NOTE:

ALL BACKFLOW PREVENTION ASSEMBLIES SHALL BE DELIVERED FOR INSTALLATION COMPLETELY ASSEMBLED BY THE ORIGINAL MANUFACTURER WITH ALL COMPONENTS AS APPROVED.

NOTE:

ADDITION OF BACKFLOW DEVICE ONTO EXISTING FIRE SUPPRESSION SYSTEMS WILL AFFECT ORIGINAL FLOW CALCULATIONS.

FIRE PUMP
(TO HAVE LOW SUCTION CUT-OFF)

RIGID FLANGE NO ADAPTORS
6" MIN. FROM WALL OR FLOOR

ANCHOR TO WALL OR SLAB

SUPPLY

THRUST BLOCK

A.S.S.E. 1048 DOUBLE DETECTOR CHECK VALVE WITH APPROVED INDICATING VALVES. DETECTOR METER TO READ IN CUBIC FEET.

CLASS 53 DUCTILE IRON TO VALVE
ALL JOINTS RESTRAINED.

TO FIRE SYSTEM

N.	DATE	REVISIONS
1	3/07	NOTES
2	7/19	NOTES

FIRE SUPPRESSION SYSTEMS

STANDARD DRAWING
DEPT. OF WATER ENGINEERING
CITY OF DAYTON

SCALE: NOT TO SCALE
DRAWN: 07-1999 BY: JBS

REDUCED PRESSURE DETECTOR ASSEMBLY (R.P.D.A.) WITH ANTI-FREEZE LOOPS

NOTE:

ALL BACKFLOW PREVENTION ASSEMBLIES SHALL BE DELIVERED FOR INSTALLATION COMPLETELY ASSEMBLED BY THE ORIGINAL MANUFACTURER WITH ALL COMPONENTS AS APPROVED.

NOTE:

ANTI-FREEZE SOLUTION MUST BE NON-TOXIC, USE ETHYLENE GLYCOL.

RIGID FLANGE NO ADAPTORS
6" MIN. FROM WALL OR FLOOR

ANCHOR TO WALL OR SLAB

SUPPLY

CLASS 53 DUCTILE IRON TO VALVE
ALL JOINTS RESTRAINED.

THRUST BLOCK

A.S.S.E. 1047 REDUCED PRESSURE
DETECTOR CHECK VALVE WITH APPROVED
INDICATING VALVES. DETECTOR METER TO
READ IN CUBIC FEET.

TO FIRE SYSTEM
WITH ANTI-FREEZE
LOOPS

NOTE:

ADDITION OF BACKFLOW DEVICE ONTO EXISTING
FIRE SUPPRESSION SYSTEMS WILL AFFECT
ORIGINAL FLOW CALCULATIONS.

GENERAL NOTE:
CONTACT WATER ENGINEERING FOR ANY
SITUATION NOT COVERED IN STANDARDS

N.	DATE	REVISIONS
1	3/07	DETECTOR
2	7/19	NOTES

FIRE SUPPRESSION
SYSTEM

STANDARD DRAWING
DEPT. OF WATER ENGINEERING
CITY OF DAYTON

SCALE: NOT TO SCALE
DRAWN: 07-1999 BY: JBS

YARD MAIN SYSTEM ARRANGEMENT

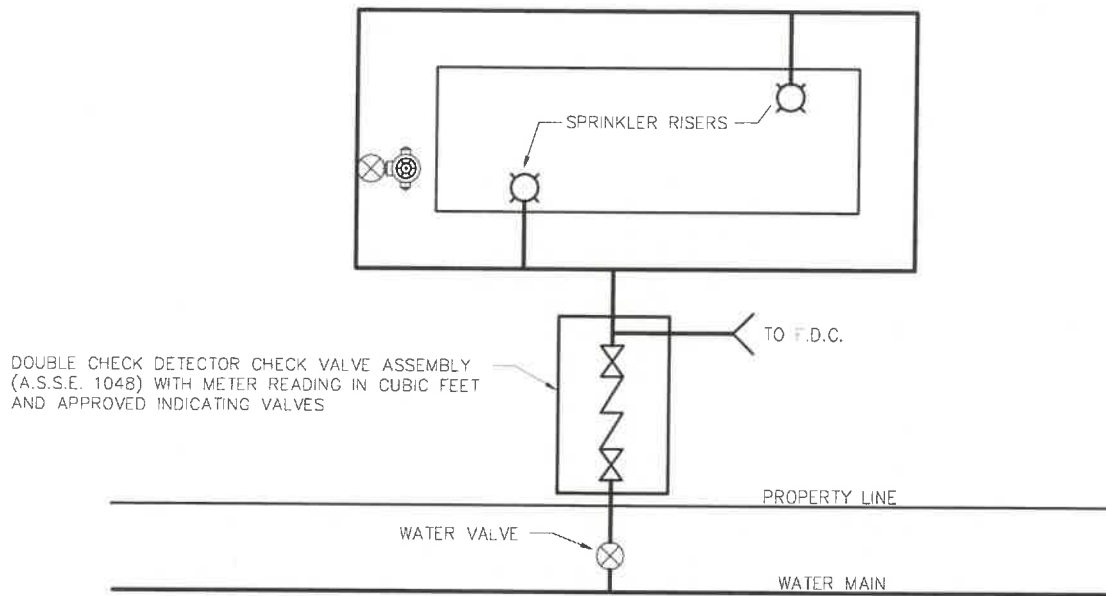

LIMITED AREA SPRINKLER SYSTEM

NOTE:

ADDITION OF BACKFLOW DEVICE ONTO EXISTING FIRE SUPPRESSION SYSTEMS WILL AFFECT ORIGINAL FLOW CALCULATIONS.

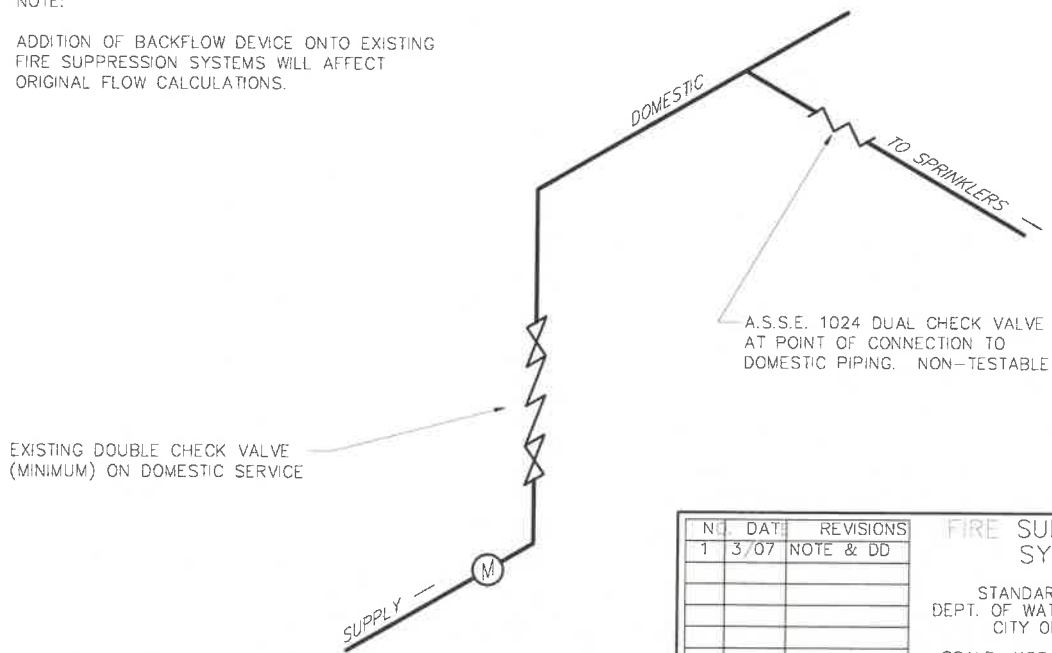

NO.	DATE	REVISIONS
1	3/07	NOTE & DD

FIRE SUPPRESSION SYSTEMS

STANDARD DRAWING
DEPT. OF WATER ENGINEERING
CITY OF DAYTON

SCALE: NOT TO SCALE
DRAWN: 07-1999 BY: JBS

LIMITED AREA SPRINKLER SYSTEM FROM EXISTING DOMESTIC WITH NO BACKFLOW DEVICE REQUIRED

NOTE:

ADDITION OF BACKFLOW DEVICE ONTO EXISTING
FIRE SUPPRESSION SYSTEMS WILL AFFECT
ORIGINAL FLOW CALCULATIONS.

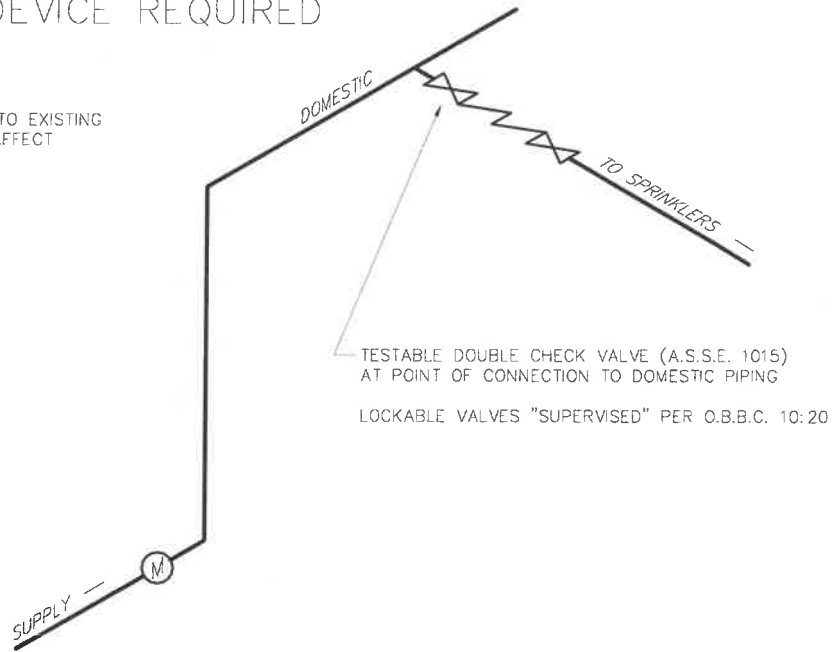

LIMITED AREA SPRINKLER SYSTEM

NOTE:

ADDITION OF BACKFLOW DEVICE ONTO EXISTING
FIRE SUPPRESSION SYSTEMS WILL AFFECT
ORIGINAL FLOW CALCULATIONS.

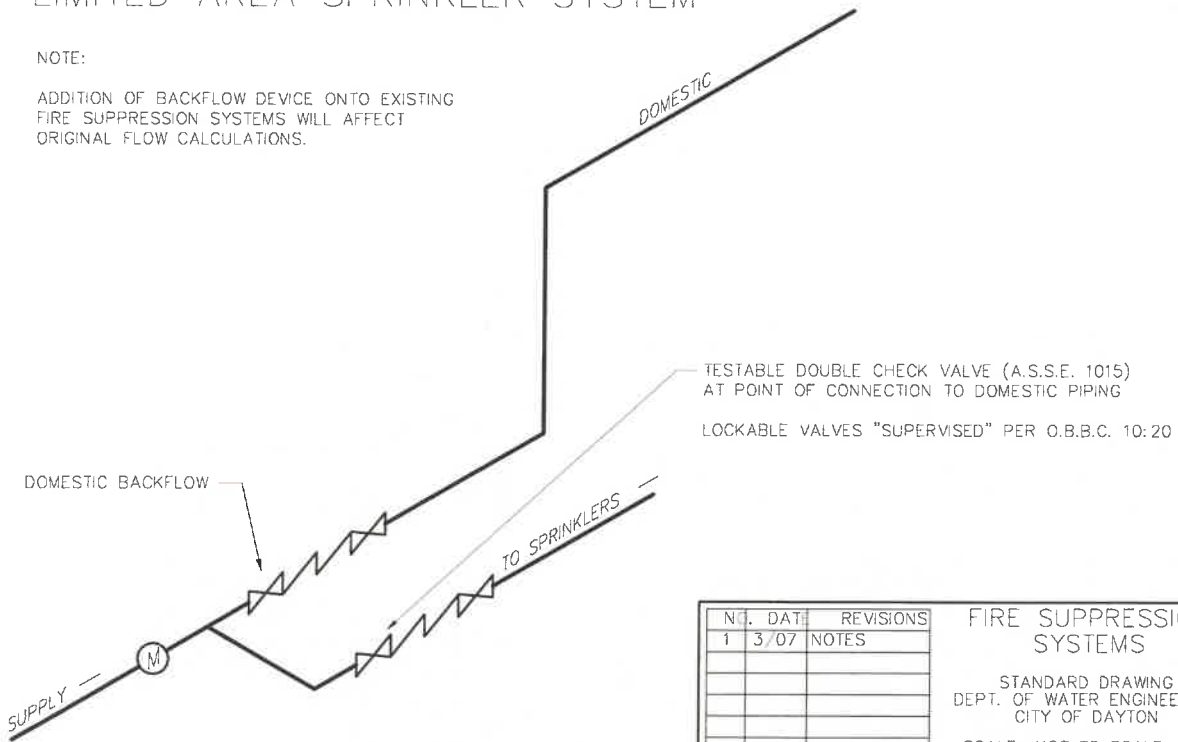

N.	DATE	REVISIONS
1	3/07	NOTES

FIRE SUPPRESSION SYSTEMS

STANDARD DRAWING
DEPT. OF WATER ENGINEERING
CITY OF DAYTON

SCALE: NOT TO SCALE
DRAWN: 07-1999 BY: JBS

CITY OF DAYTON REQUIREMENTS FOR INSTALLING METERS AND BACKFLOW PREVENTERS FOR IRRIGATION

1. MAKE A DRAWING OF THE PROPOSED IRRIGATION SYSTEM. THIS NEEDS TO BE SUBMITTED TO THE WATER ENGINEERING DIVISION FOR APPROVAL BEFORE WORK BEGINS. FOR COUNTY INSTALLATIONS OUTSIDE CITY LIMITS BOARD OF HEALTH PLUMBING INSPECTION MUST APPROVE FIRST.
2. FOLLOW THE CITY OF DAYTON "STANDARDS FOR TAPS, SERVICES AND METERS". ALL WORK MUST BE DONE IN ACCORDANCE WITH THIS STANDARD
3. GET NECESSARY PERMITS BEFORE WORKS BEGINS:

	<u>IN DAYTON</u>	<u>OUTSIDE DAYTON</u>
WATER SERVICE PERMIT	DAYTON	DAYTON
METER SET FEE	DAYTON	DAYTON
PLUMBING PERMIT	DAYTON	COUNTY COMBINED HEALTH DISTRICT

4. RETURN COMPLETED FORMS AFTER THE BACKFLOW PREVENTERS HAVE BEEN TESTED, PLEASE FILL OUT COMPLETELY WITH THE FOLLOWING:

OWNER/LESSEE'S NAME,
ADDRESS (WHERE THE BACKFLOW PREVENTER WAS INSTALLED)
LOCATION OF THE BACKFLOW PREVENTER
SIZE, MAKE, MODEL AND SERIAL NUMBER OF THE BACKFLOW PREVENTER

PLEASE RETURN THE COMPLETED FORMS TO:

CITY OF DAYTON
DEPARTMENT OF WATER
320 W. MONUMENT AVE.
DAYTON, OHIO 45402

ATTN: WATER ENGINEERING
CUSTOMER RELATIONS

RE: BACKFLOW

5. CONTACT WATER ENGINEERING AFTER THE WORK HAS BEEN COMPLETED. BACKFLOW PREVENTERS HAVE TO BE INSPECTED BY WATER ENGINEERING.

N.	DATE	REVISIONS
1	3/07	NOTES

IRRIGATION
BACKFLOW

STANDARD DRAWING
DEPT. OF WATER ENGINEERING
CITY OF DAYTON

SCALE: NOT TO SCALE
DRAWN: 07-1999 BY: JBS

D-30

HOSE BIBB

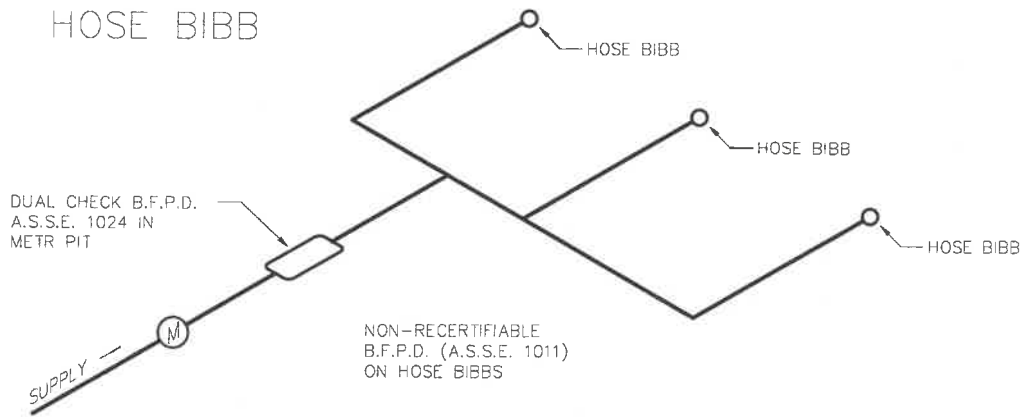

D-31

YARD HYDRANT

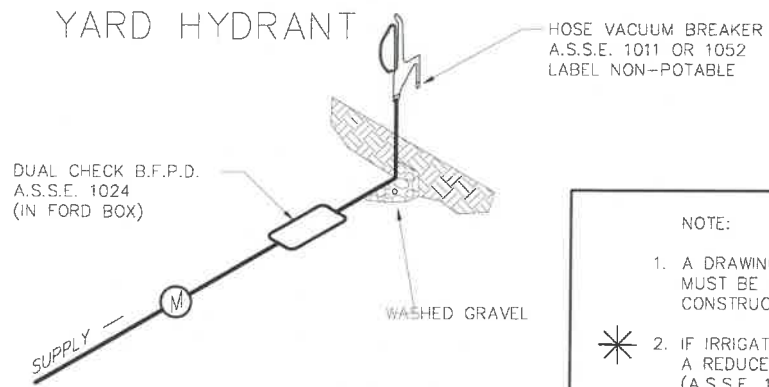

NOTE:

1. A DRAWING OF EACH PROPOSED IRRIGATION SYSTEM MUST BE APPROVED BY WATER ENGINEERING PRIOR TO CONSTRUCTION.
2. IF IRRIGATION SYSTEM IS NONE OF THESE SHOWN, USE A REDUCED PRESSURE BACKFLOW PREVENTER, (A.S.S.E. 1013), AFTER THE WATER METER.

D-32

IRRIGATION SYSTEM

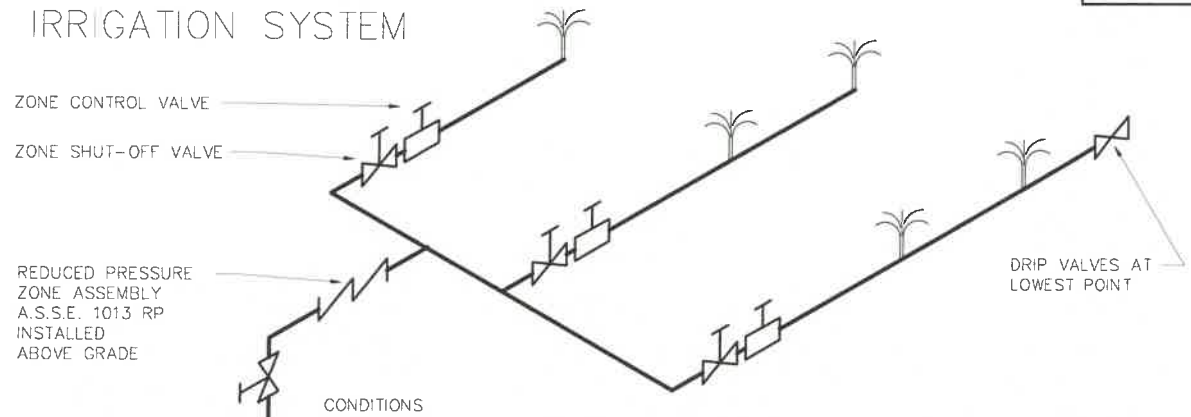

CONDITIONS
 SHUT OFF VALVES ARE ALLOWED
 DOWNSTREAM OF THE B.F.P.D.
 THE PRESSURE TYPE VACUUM
 BREAKER MUST BE A MINIMUM
 OF 12" ABOVE GRADE.

NO.	DATE	REVISIONS
1	3/07	NOTES & DD

5/8" TO 1"
 IRRIGATION METERS
 STANDARD DRAWING
 DEPT. OF WATER ENGINEERING
 CITY OF DAYTON
 SCALE: NOT TO SCALE
 DRAWN: 07-1999 BY: JBS

5/8" - 1" IRRIGATION METER STANDARD INSTALLATION

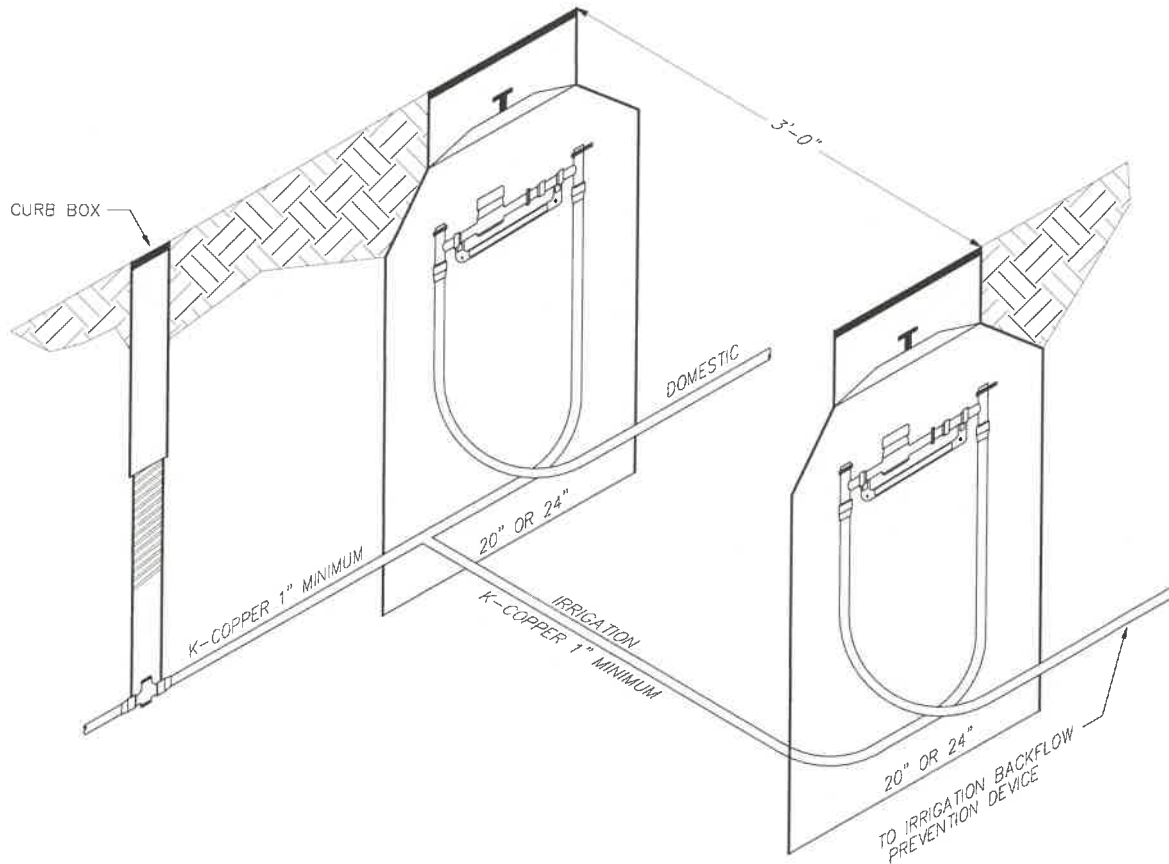

NOTES:

1. SEE "STANDARDS FOR TAPS, SERVICES AND METERS" FOR TYPICAL NOTES.
2. BACKFLOW PREVENTION DEVICE REQUIRED - CONTACT WATER ENGINEERING FOR APPROVED DEVICE.
3. ABSOLUTELY NO "DEDUCT" METER INSTALLATION.
4. ALTERNATE DESIGNS MUST BE SUBMITTED FOR APPROVAL.
5. TOP OF PIT TO BE INSTALLED AT FINISHED GRADE.
6. NO OUTLETS ARE ALLOWED BETWEEN THE METER AND THE BACKFLOW PREVENTER OR HOSE BIBB VACUUM BREAKER WITH THE EXCEPTION OF ONE SCREW-IN PLUG FOR WINTERIZING/DRAINAGE PURPOSES.
7. THE UNDERGROUND WATER SERVICE SHALL BE K-COPPER UP TO THE METER. ALL JOINTS MUST BE FLARED TYPE JOINTS.
8. THE INSTALLATION IS SUBJECT TO INSPECTION BY BOTH PLUMBING INSPECTION AND WATER DEPARTMENT PERSONNEL.
9. TWO 5/8" METERS MAY BE INSTALLED IN ONE 24" PIT.

NO.	DATE	REVISIONS
1	11/00	GRAPHICS
2	3/07	1" LOCATION

IRRIGATION METER
INSTALLATION

STANDARD DRAWING
DEPT. OF WATER ENGINEERING
CITY OF DAYTON

SCALE: NOT TO SCALE
DRAWN: 07-1999 BY: JBS

WATER PIT NOTES:

- A. DIMENSIONS SHOWN ARE INSIDE MEASUREMENTS.
- B. ALL PIPE WITHIN THE METER PIT AND TO THE CITY OWNED MAIN SHALL BE CLASS 53 DUCTILE IRON PIPE. PIPE WITHIN THE METER PIT SHALL HAVE FLANGED ENDS.
- C. ALL VALVES SHALL BE FLANGED END, HANDWHEEL OPERATED, O.S. & Y. GATE VALVES.
- D. PIT SHALL HAVE AN INSIDE HEIGHT OF 6' MINIMUM.
- E. PIT TO BE PRE-CAST CONSTRUCTION OR CAST-IN PLACE WITH 6' CONCRETE FLOOR SLAB AND SUMP PIT. ROOF TO BE 8" PRE-CAST OR DESIGNED BY A PROFESSIONAL ENGINEER.
- F. BACKFLOW PREVENTER TO BE RECERTIFIED AT TIME OF INSTALLATION.
- G. METER SPREAD AND DOUBLE DETECTOR CHECK VALVE VERTICAL CLEARANCE 18" MINIMUM AND 36" MAXIMUM OFF FLOOR OF PIT.
- H. PIPING, METER, AND CHECK VALVE SHALL BE SUPPORTED AS APPROVED BY WATER ENGINEERING.

⬡ CODED NOTES:

- ① O.S. & Y. GATE VALVE
- ② ASSE 1048 DOUBLE DETECTOR CHECK BACKFLOW PREVENTER WITH RESILIENT SEATED O.S. & Y. VALVES. WATER METER TO BE READ IN CUBIC FEET. PROVIDE REMOVABLE PLUGS IN TEST COCKS.
- ③ METER SPREAD BASED ON METER SIZE.
- ④ STEPS—CAST IRON OR ALUMINUM OR POLYPROPYLENE AT 12" O.C.
- ⑤ SUMP DRAIN TO STORM MANHOLE 1'x1'x1'.
- ⑥ 6"x4" TEE
- ⑦ 4"x4" TEE
- ⑧ PIPE ANCHORED TO WALL WITH RETAINER GLAND OR WALL SLEEVE.
- ⑨ RESTRAINED M.J. BELL WITHIN 2' OF WALL.
- ⑩ METAL DOOR 48"x48" PER CITY SPECIFICATIONS CENTERED ON METER SPREAD.
- ⑪ 6"x6"x6" TEE.
- ⑫ BALL DRIP CHECK VALVE.
- ⑬ SIAMESE CONNECTION.
- ⑭ POST INDICATOR VALVE WITH SUPERVISORY SWITCH.
- ⑮ O.S. & Y. GATE VALVE WITH SUPERVISORY SWITCH.

NOTE:
SEE SHEET No. D-34-A
FOR WATER METER PIT DETAIL.

NO.	DATE	REVISIONS

WATER METER PIT
DETAIL NOTES

STANDARD DRAWING
DEPT. OF WATER ENGINEERING
CITY OF DAYTON

SCALE: NOT TO SCALE
DRAWN: 6-2019 BY: AK

COMBINATION FIRE AND DOMESTIC METER PIT INSTALLATION/2 METERS AND FIRE LINE BACKFLOW PREVENTOR 2" AND LARGER

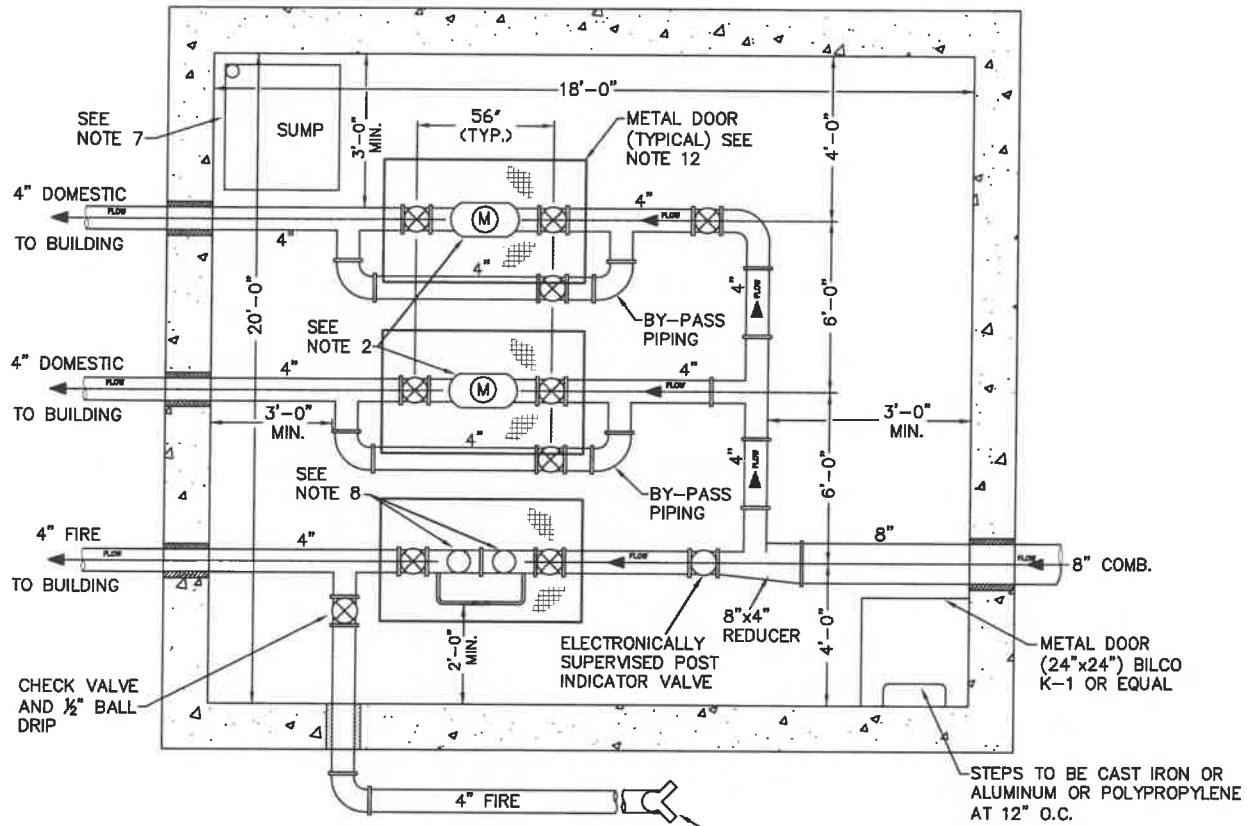

PLAN VIEW

NOTES:

1. REFER TO CITY OF DAYTON WATER DEPARTMENT STANDARDS FOR METER PIT SETTING REQUIREMENTS. STANDARD DRAWING #D-20.
2. CITY OF DAYTON WATER DEPARTMENT APPROVED WATER METER.
3. PROVIDE 12"x12" CONCRETE SUPPORTS (3000 PSI CONCRETE) WITH #3 BARS IN CORNERS DOWELED INTO FLOOR SLAB ALL VALVES. PROVIDE HARDWOOD BLOCK BETWEEN CONCRETE SUPPORT AND VALVE.
4. PROVIDE WATERTIGHT CONNECTION AT ALL PIPES. PROVIDE LINK-SEAL TYPE WALL PENETRATION SEAL.
5. PROVIDE CONCRETE VAULT ABLE TO WITHSTAND H-20 WHEEL LOADS TO THE DIMENSIONS SHOWN.
6. ALL PIPE SHALL BE CLASS 53 WITH FLANGE CONNECTIONS IN ACCORDANCE WITH CITY OF DAYTON WATER DEPARTMENT.
7. CONNECT 2" PUMP DISCHARGE DRAIN TO STORM SEWER.
8. 4" WATTS SERIES 709DCDA DOUBLE CHECK DETECTOR ASSEMBLY (OR APPROVED EQUAL).

NO.	DATE	REVISIONS

WATER METER PIT
DETAIL
STANDARD DRAWING
DEPT. OF WATER ENGINEERING
CITY OF DAYTON
SCALE: NOT TO SCALE
DRAWN: 6-2019 BY: A.K.

SINGLE METER AND BACKFLOW PREVENTER FOR 2" AND LARGER

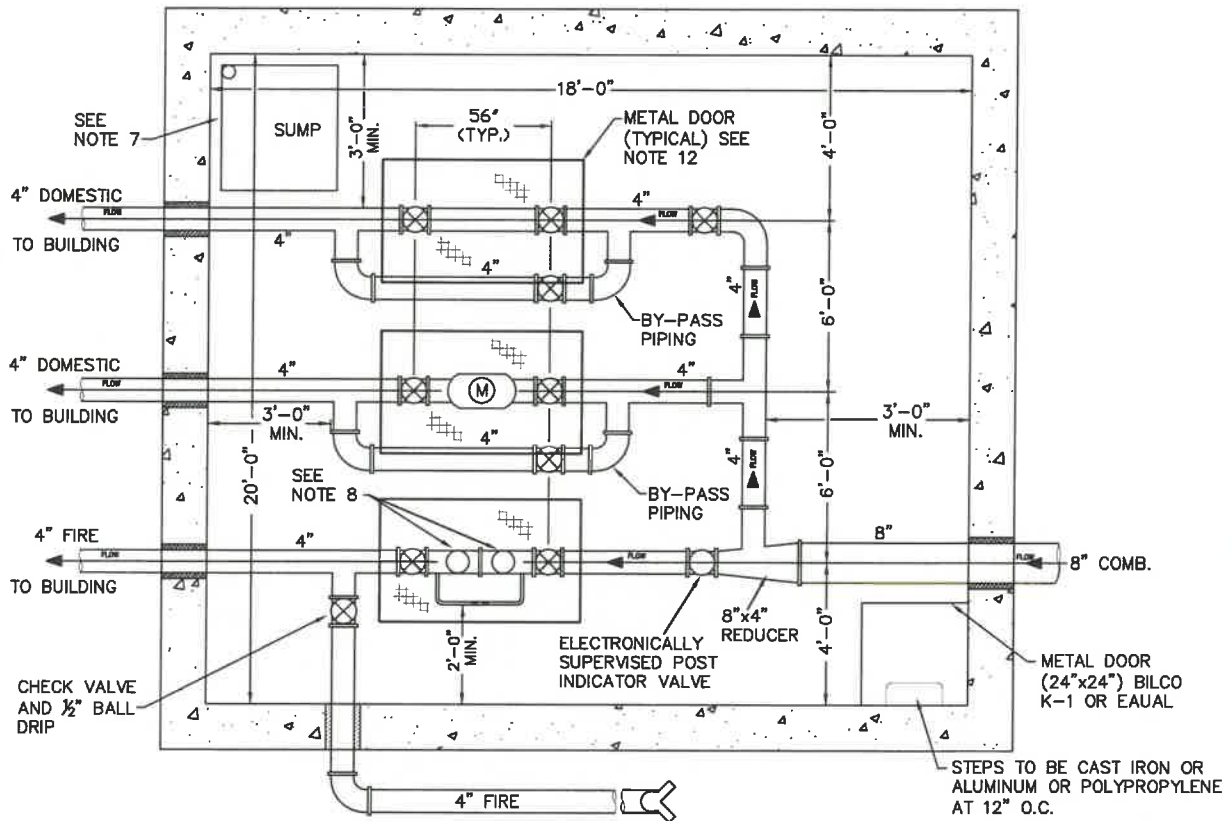

PLAN VIEW

POST TYPE SIAMESE. COORDINATE WITH DAYTON FIRE DEPARTMENT FOR FITTINGS TYPE. FIND LOCATION AT OUTSIDE OF FENCE LINE.

NOTES:

1. REFER TO CITY OF DAYTON WATER DEPARTMENT STANDARDS FOR METER PIT SETTING REQUIREMENTS. STANDARD DRAWING #D-20.
2. CITY OF DAYTON WATER DEPARTMENT APPROVED WATER METER.
3. PROVIDE 12"x12" CONCRETE SUPPORTS (3000 PSI CONCRETE) WITH #3 BARS IN CORNERS DOWELED INTO FLOOR SLAB ALL VALVES. PROVIDE HARDWOOD BLOCK BETWEEN CONCRETE SUPPORT AND VALVE.
4. PROVIDE WATERTIGHT CONNECTION AT ALL PIPES. PROVIDE LINK-SEAL TYPE WALL PENETRATION SEAL.
5. PROVIDE CONCRETE VAULT ABLE TO WITHSTAND H-20 WHEEL LOADS TO THE DIMENSIONS SHOWN.
6. ALL PIPE SHALL BE CLASS 53 WITH FLANGE CONNECTIONS IN ACCORDANCE WITH CITY OF DAYTON WATER DEPARTMENT.
7. CONNECT 2" PUMP DISCHARGE DRAIN TO STORM SEWER.
8. 4" WATTS SERIES 709DCDA DOUBLE CHECK DETECTOR ASSEMBLY (OR APPROVED EQUAL).

NO.	DATE	REVISIONS

WATER METER PIT
DETAIL
STANDARD DRAWING
DEPT. OF WATER ENGINEERING
CITY OF DAYTON
SCALE: NOT TO SCALE
DRAWN: 6-2019 BY: A.K.